



**ELEVETTE  
500 lb. CABLE DRUM  
With UC601 CONTROL SYSTEM  
MECHANICAL INSTALLATION  
INSTRUCTIONS**

**ELEVATOR INSTALLERS MUST INSTALL THIS ELEVATOR  
AND ALL ITS COMBINED EQUIPMENT TO COMPLY WITH  
ASME A17.1, N.E.C., AND ALL APPLICABLE NATIONAL,  
STATE, AND LOCAL CODES.**

**601 Gibson Blvd.  
HARRISBURG, PA 17104  
PHONE: 1-800-343-9007 (M-F 8am-5pm EST)  
FAX: 717-939-8076 / 8075  
[www.inclinator.com](http://www.inclinator.com)**



## CAUTION

### FAMILIARIZE YOURSELF WITH THESE INSTRUCTIONS

#### **THIS ELEVATOR MUST BE INSTALLED TO COMPLY WITH ALL NATIONAL, STATE, AND LOCAL CODES.**

- Installers are cautioned that there are many potential hazards involved in the installation of Elevators and Dumbwaiters. Accidents may be disabling or fatal. Installers should be reminded of the hazards involved.
- Installers should never work alone. There are safety in numbers. Installers should always be aware of their fellow installers presence and the area in which they are working.
- Installers should be properly clothed before starting the installation. Wearing loose clothing should be avoided. Keep all buttons, particularly ones on cuffs, buttoned at all times.
- Installers should be aware of the fact that objects may fall in a shaftway at any time. Proper head protection should be worn.
- Shaft doors should be locked or nailed shut any time an area is left unattended and door interlocks are not installed.
- Extreme care should be exercised when working overhead, in the pit, or around an elevator platform when power is applied.
- Power should be removed from the controller and operating systems before any electrical work is attempted.
- Installers should never enter an elevator pit when it contains water or work in a machine room which has a wet floor. Accidents from electric shock have occurred under these conditions, and sometimes fatal.
- When elevator car is not parked on a switch, and is called or sent, direction of travel cannot be determined.
- All installers should read and understand a current Elevator Safety Handbook prior to installation.
- Turn power off at the 208/240 VAC disconnect, the 110-120 VAC disconnect, and turn off the UPS inside the CPU control enclosure prior to making any adjustments on the elevator.
- Installers should never place themselves in a position where they may be harmed, such as near rotating machinery, between shear points, under heavy objects, etc.
- Installers repairing or adjusting equipment they do not understand should contact the manufacturer prior to making any adjustments or repairs.

**NOTE:** All statements, technical information and recommendations contained herein are based on data believed to be reliable, but the accuracy or completeness thereof is not guaranteed.

## **WARNING**

- 1. Never run this elevator on temporary power. Make certain power supplied to the elevator system is the same as printed on the face of the controller.**
- 2. When installing elevator, write on the inside of the controller lid the voltage supplied to the elevator when under power on L1 and L2. This will help in troubleshooting later.**
- 3. Never push in contactors to run elevator, use jog switch.**
- 4. Controllers are designed for indoor use only. Never expose the Controller to the elements.**

## Table of Contents

GETTING STARTED.....	4
PREPARATION TO GUIDE RAIL INSTALLATION.....	4
GUIDE RAIL INSTALLATION .....	4
TROLLEY INSTALLATION .....	7
MOUNTING GEARBOX & SHEAVES.....	8
INSTALLING DRUMS .....	10
HANDWHEEL AND MOTOR INSTALLATION.....	11
RECOMMENDED MINIMUM DRUM TO SHEAVE DISTANCE .....	12
PLACEMENT OF CENTER OF PLANK AND FLAT BRACKET W/ANGLE SHEAVES.	17
THREADING SUSPENSION CABLES.....	18
INSTALLING CAR BASE .....	19
LUBRICATING GUIDE RAIL.....	19
INSTALLING WOOD CAB .....	20
INSTALLING 500 STYLE CAB.....	21
500 Cab DISASSEMBLY INSTRUCTIONS:.....	21
500 Cab Assembly Instructions.....	23
TOE GUARD INSTALLATION .....	24
STABILIZER RAIL INSTALLATION (OPTIONAL).....	24
INSTALLING CAR HALF TROLLEY (OPTIONAL).....	26
MOUNTING DISCONNECT SWITCH & CONTROLLER .....	29
BRAKE WIRING CONNECTIONS .....	29
SLACK CABLE ASSEMBLY .....	31
<b>INSTALLATION OF LANDING DOOR FRAME OR PRE-HUNG DOOR KITS.....</b>	<b>32</b>
<b>INSTALLATION OF DOOR INTERLOCKS .....</b>	<b>33</b>
<b>INTERLOCK WIRING INSTRUCTIONS .....</b>	<b>37</b>
<b>DOOR INTERLOCK EMERGENCY ACCESS.....</b>	<b>38</b>

## GETTING STARTED

Carefully review plans and schematics. A well thought out plan should be developed prior to starting the installation. Be sure to only use prints marked final, as the order details are complete and no change is expected. Bear in mind that the drawings are used for ordering materials, for guiding manufacture of the unit, for the door manufacturer, for the architect, for the steel designer, for the builder, for the state and local code authority, for future alterations, and for the job file. Remember that the drawing(s) are a very important tool. Use extreme care.

Unpack and check parts against bills of materials, packing slips, job sheets, etc. Be sure to call Inclinor for any discrepancies. Check the condition of parts when they arrive, and determine whether any damage may have occurred during shipping, manufacture, or out in the field.

## PREPARATION TO GUIDE RAIL INSTALLATION

1. If not installed by the general contractor, a 2 x 12 wood plank must be installed on the support wall before the guide rail can be installed. The plank must extend from the pit floor to the top of the shaft. The wood should be well seasoned, a good grade (#1) with little or no warping in the lumber.
2. Determine where the centerline of the plank and/or guide rail should be located in the hoistway. Always make measurements from a gate-side wall. The centerline location will be noted on the shop drawing or can be determined by adding half the car width to the running clearance, ( $\text{car width}/2 + \text{running clearance} = \text{centerline location of plank and guide rail}$ ). In the hoistway, mark the centerline location on the support wall about 12" above the pit floor and about the same distance down from the top of the hoistway. Drop a plumb bob to see if the centerlines are the same. Adjust if necessary. Use a chalk line to mark the centerline location from the top to the bottom of the hoistway.
3. Once the plank location is determined, install the 2 x 12 plumb and square extending from the pit to the top of the hoistway. If applicable, install the plank with the concave side facing out from the wall. Use 3/8" x 5" long lags spaced every 2 ft. to secure the plank to the support wall. Locate the bolts about 1" in from the sides plank and counter-bore the holes so the head of the bolts are below the surface of the 2 x 12.

## GUIDE RAIL INSTALLATION

Use the procedure described in the above section for locating the guide rail centerline. **Do not assume the plank centerline is also the centerline for the rail.** Strike a chalk line from the top to the bottom of the plank where the true rail center should be in the hoistway.

**NOTE: IT IS IMPORTANT THAT THE RAILS ARE INSTALLED PROPERLY TO INSURE THE BEST POSSIBLE FIT AND CAR RIDE. RAILS MUST BE FREE OF DIRT PRIOR TO INSTALLING TROLLEY.**

## GUIDE RAIL INSTALLATION (Cont.)

1. Identify the rail sections. The main guide rail consists of two or more sections that are assembled together in the hoistway. If there are only two (2) rail sections, the lower section will have two (2) 3/8 diameter pins in each splice block. The upper section will have splice blocks with clearance holes that align with the pins.
2. If there are three or more rail sections, there will be a label identifying the mating splice sections as shown below. The bottom rail splice will be labeled splice "1"

**NOTE: ALWAYS START AT THE BOTTOM OF THE SHAFT WITH THE SMALLEST SPLICE NUMBER (UNLESS OTHERWISE SPECIFIED).**

**IMPORTANT: Install both the trolley and upper axle into the rail after installing the bottom rail section and before installing the remaining rails. See page 7.**

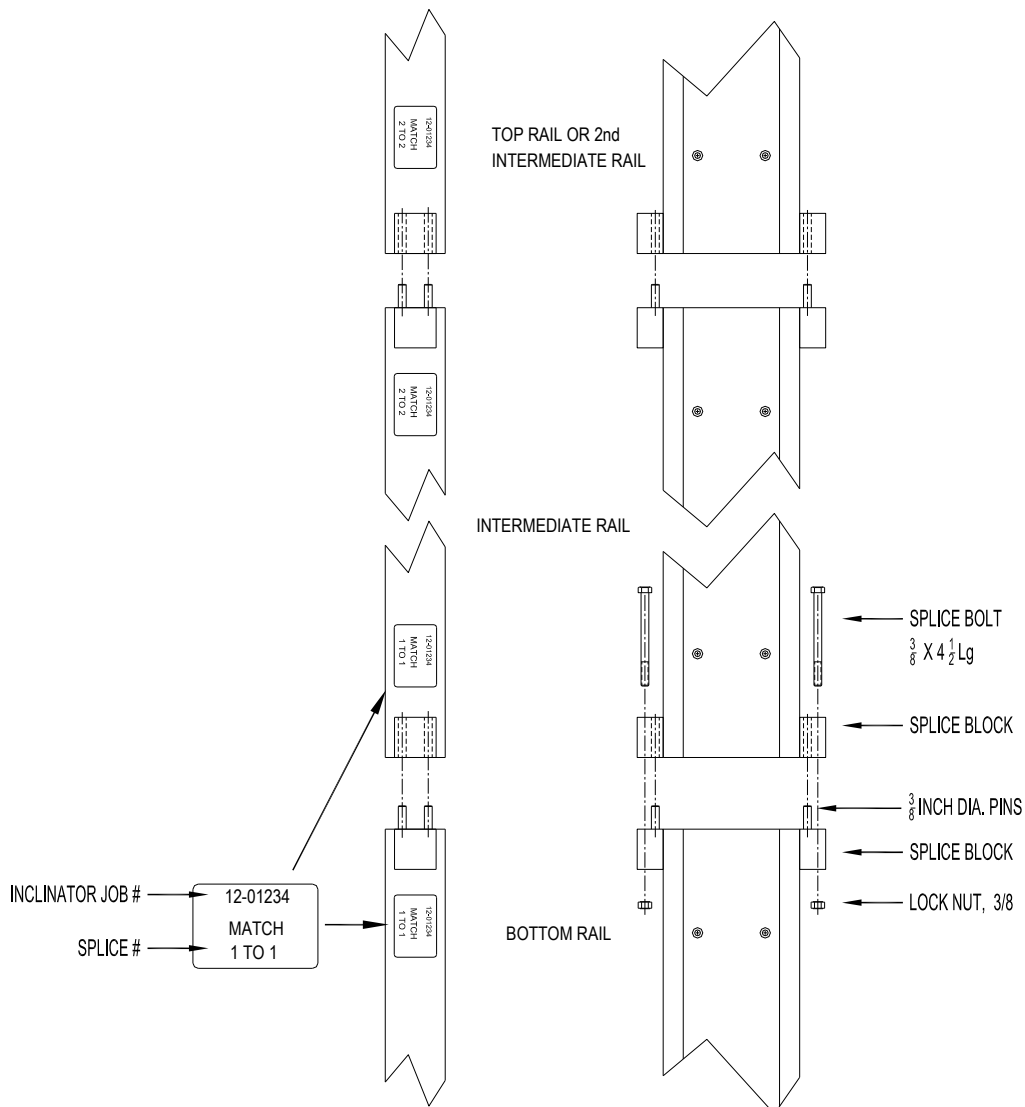

# IMPORTANT INFORMATION

## RAIL SPLICE PROCEDURE

1. INSTALL BOTTOM RAIL SECTION, DO NOT PLACE RAIL MOUNTING SCREWS IN TOP TWO SETS OF RAIL SCREW HOLES. NOTE THE BOTTOM RAIL CONTAINS FOUR (4) DOWEL PINS SHIPPED IN THE SPLICE BLOCKS.
2. LOCATE THE TOP RAIL OR THE NEXT LABELED SECTION OF RAIL BY MATCHING THE LABEL NUMBERS. (IE. 1 TO 1)
3. PLACE TOP RAIL OR NEXT LABELED SECTION OF RAIL OVER THE DOWEL PINS. THEN GUIDE THEM INTO THEIR RESPECTIVE HOLES. (FIG. 1)
4. TO CLOSE THE GAP BETWEEN THE RAILS, STRIKE THE TOP SPLICE BLOCKS WITH A BRASS HAMMER ALTERNATING FROM SIDE TO SIDE. REPEAT UNTIL THE RAIL SECTIONS ARE TOGETHER ENOUGH TO INSERT THE SPLICE BOLTS AND START THE STOVER NUTS.

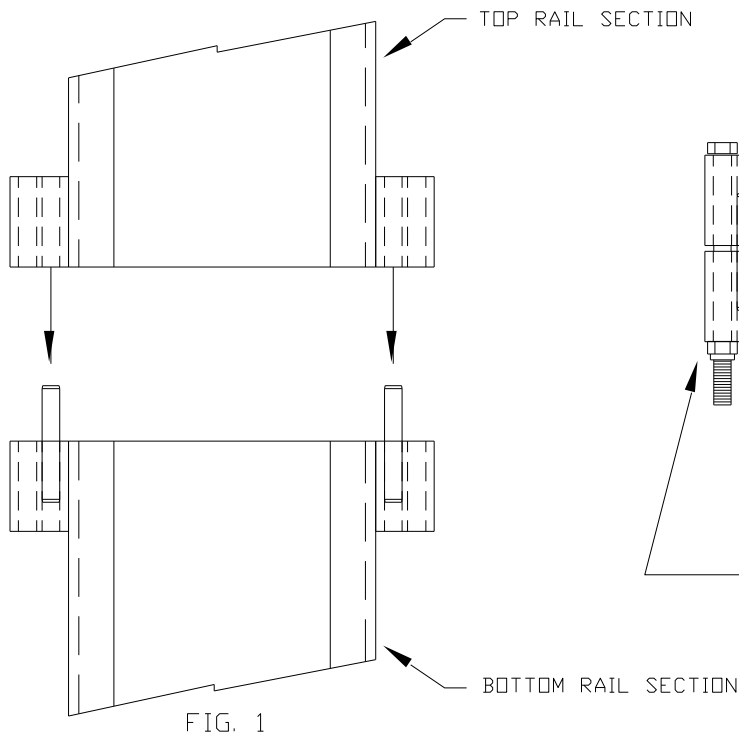

FIG. 1

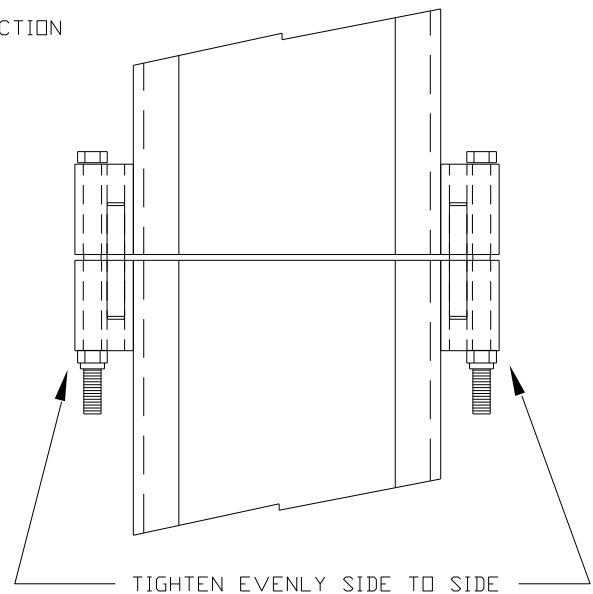

FIG. 2

5. TIGHTEN THE STOVER NUTS DOWN EVENLY ALTERNATING FROM SIDE TO SIDE. (FIG. 2)
6. IF NEEDED, FINISH DRIVING THE DOWEL PINS DOWN UNTIL THEY ARE FLUSH WITH THE SPLICE BLOCK.
7. INSTALL RAIL MOUNTING SCREWS ON EACH SIDE OF RAIL SPLICE AND IN THE TOP RAIL SECTION.
8. CHECK THE INSIDE RAIL SURFACES AT THE SPLICE LOCATION TO MAKE SURE THESE SURFACES ARE FLUSH.
9. REPEAT THIS PROCEDURE (STEPS 1 THRU 8) FOR MULTIPLE SPLICE JOBS.

**IMPORTANT: There must be at least 14 inches between the top of the rail and the top of the hoistway. This allows installation of the rail jaw sheave.**

## TROLLEY INSTALLATION

1. Note that four (4) slide blocks are supplied. Two slide blocks are located on the upper (loose) axle and two on the lower axle mounted on the trolley plate. See below.

**NOTE: The trolley safeties will not allow the trolley to slide down the rail. Use vice grips or c-clamps to hold the safeties in.**

2. Install both trolley and upper axle in the bottom rail section before proceeding with installing the rest of the rail.

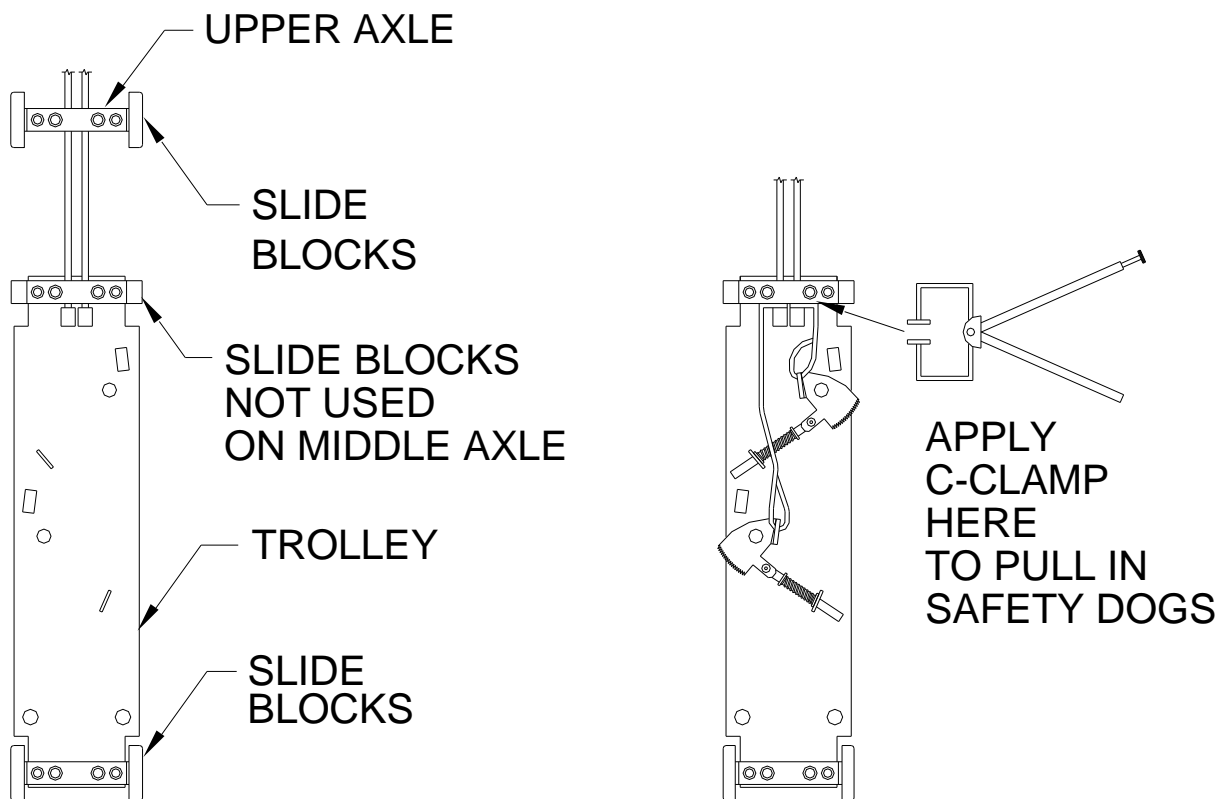



# MOUNTING GEARBOX & SHEAVES



## CAUTION

Improper mounting of the gearbox and sheaves may cause injury or death.

**NOTE:** The gear reducer is shipped from the factory filled with the proper amount of oil. With normal usage, the gear oil is good for the life of the reducer.

A Sound Base **MUST** be used to mount and properly anchor the gearmotor to the machine room floor. There are ten (10) holes in the sound base for installing anchors. **Concrete anchors must have a diameter of 1/2" and have an ultimate pull out rating of no less than 5,000 pounds.**

**For a Single Drum Machine,** Saddle Brackets may be substituted for a Sound Base when mounting on a concrete slab. See drawing on page 9 for details.

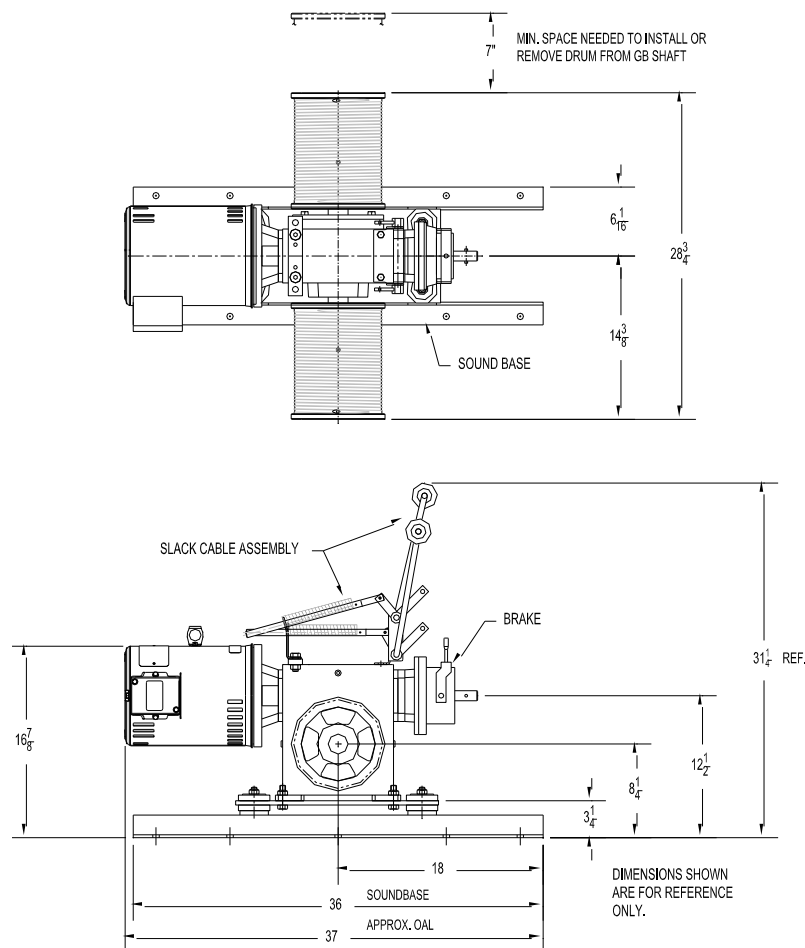

500# WD MACHINE - DOUBLE DRUM  
MOUNTED ON SOUND BASE

## MOUNTING GEARBOX & SHEAVES (CONT.)

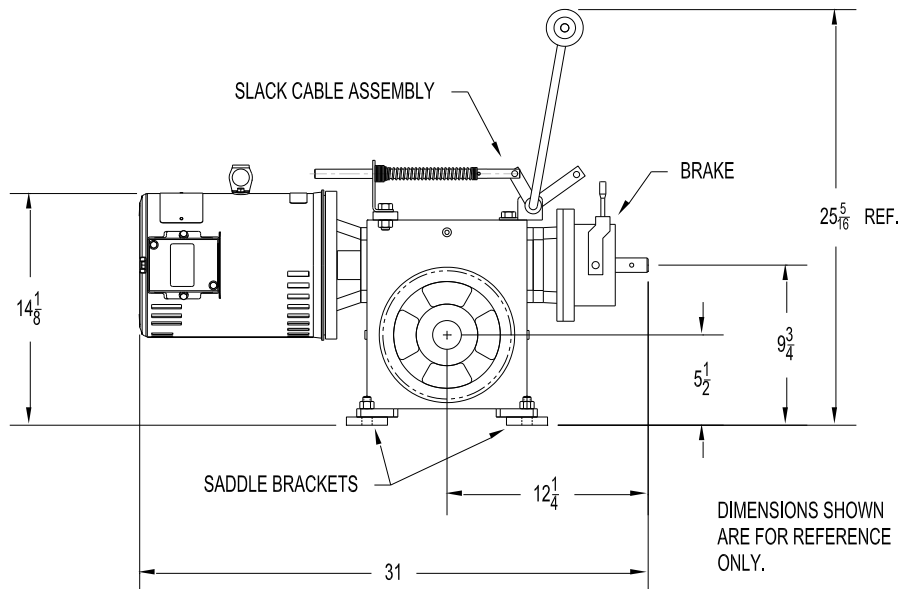
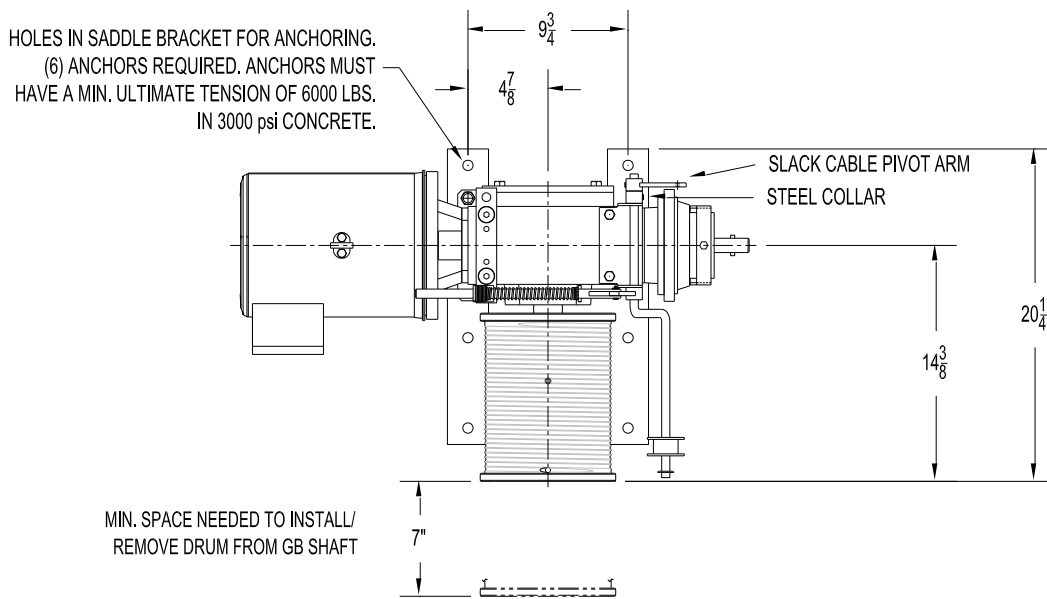

RH 500# WD MACHINE - SINGLE DRUM  
MOUNTED ON SADDLE BRACKETS

Cutout shaft walls where necessary and install all sheaves. If a rail jaw is used, place it into the top of the rail, on the correct side, as shown on the illustrations and shop drawings. For single groove, turn it in, and for double, turn it out. For other sheaves, fasten a well seasoned piece of oak or equal by lagging against the ceiling joists, removing lathe and plaster, and mount sheave bracket by boring the oak for 3/8" x 3 1/2" carriage bolts.

# INSTALLING DRUMS

The 500 lb WD machine may have a single drum or two drums. Drums for single shaft machines have double threads. Each thread has a cable start hole on the outboard end of the drum located 180 degrees apart. The drums are identified by letters stamped on the end of the drum where the Cable Start Hole is located. A 3/8" Sq. Key x 3" long must be installed in the key slot on each shaft before mounting drums. Each shaft will have a countersink mark. Locate drums so the set screw is over the c'sink. Tighten set screws with a 5/32" hex key wrench.

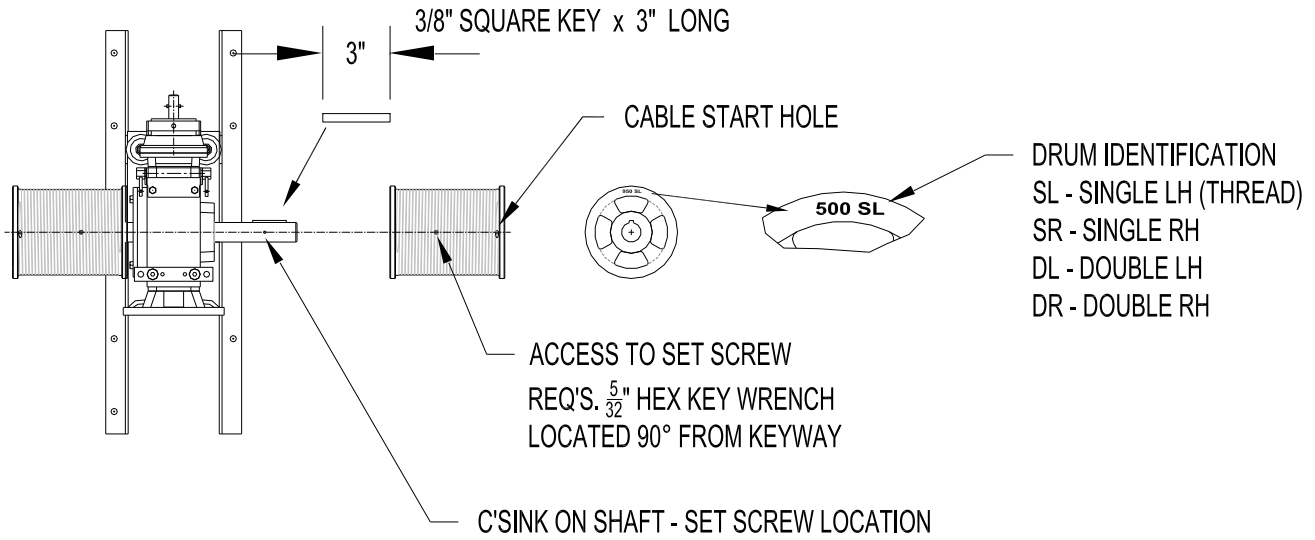

## HANDWHEEL AND MOTOR INSTALLATION

1. Install the Hand Wheel to the shaft extending out of the machine brake. Secure the hand wheel to the shaft using the  $\frac{1}{4}$ -20 x  $1\frac{3}{4}$  Lg. SHCS and  $\frac{1}{4}$ " locknut provided (Refer to drawing below).
2. The drive motor mounts to the reducer opposite the machine brake. Remove the plastic plug in the input quill. It is easier to install the motor when the key slot in the gearbox input quill is at the 12 o'clock position. Position the key slot by pushing on the brake release lever while turning the worm shaft extension with the hand wheel.
3. If not already present, apply a coating of anti-seize grease to the inside of the input quill. Place the motor key ( $\frac{1}{4}$ " Sq x  $1\frac{3}{4}$ " lg) onto the motor shaft. Align the motor key with the key slot in the quill then slide the motor shaft into the quill until the motor flange is near the mating flange on the gearbox. Rotate the motor to align the tapped holes (in the motor flange) with the holes in the gearbox flange. Install four (4)  $\frac{1}{2}$  x  $1\frac{1}{4}$ " hex head bolts along with split ring lock washers thru the gearbox flange.
4. Tighten the four (4) bolts evenly to draw the motor flange into the mating flange on the gearbox. Tighten all bolts securely.

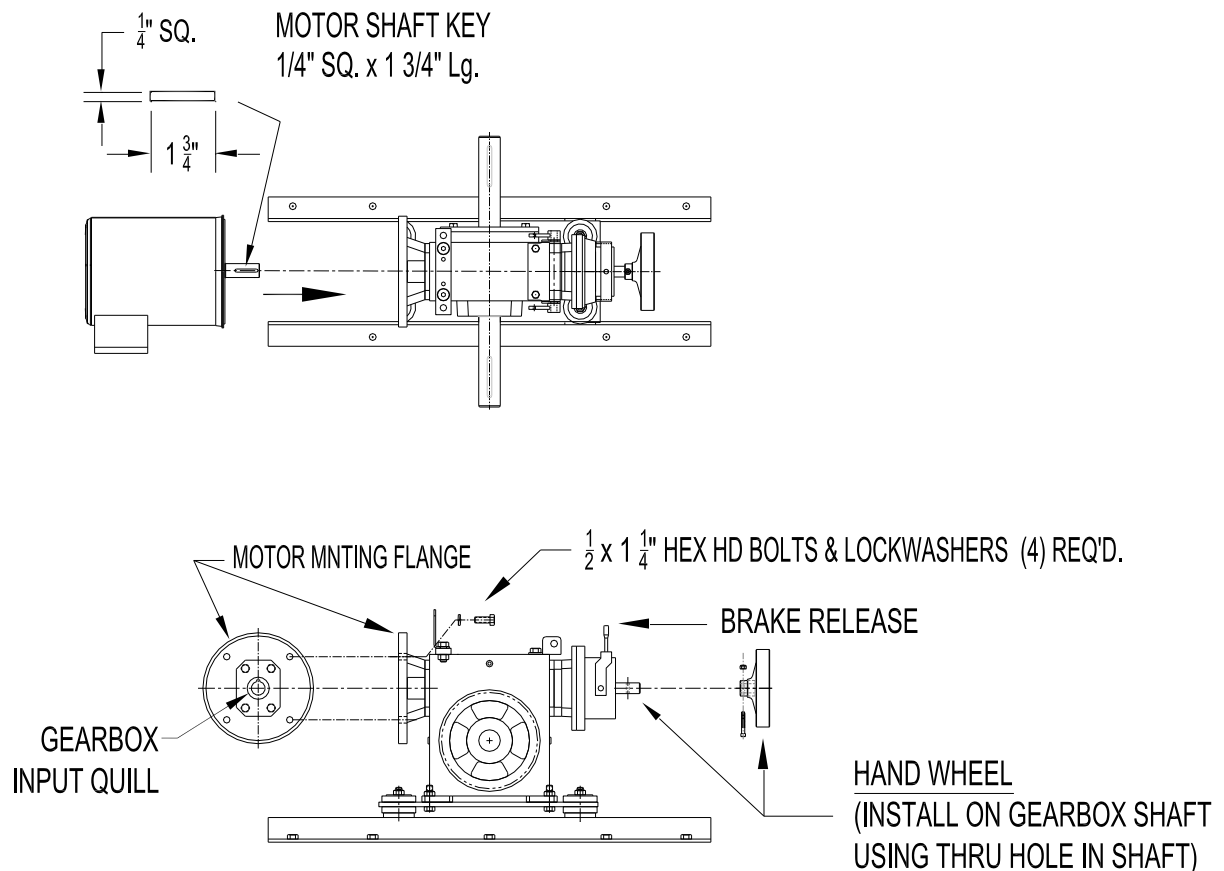

## RECOMMENDED MINIMUM DRUM TO SHEAVE DISTANCE

		Minimum Distance from Drum to 1st. Sheave			
TRAVEL		Single Drum Double Groove	Double Drum Single Groove	TRAVEL	Minimum Distance from Drum to Sheave
				Double Drum Single Groove	
8'-0"		3'-8"	1'-9"	26'-0"	5'-2"
8'-6"		3'-10"	1'-10"	27'-0"	5'-4"
9'-0"		4'-1"	1'-11"	28'-0"	5'-7"
9'-6"		4'-3"	2'-0"	29'-0"	5'-9"
10'-0"		4'-5"	2'-1"	30'-0"	5'-11"
10'-6"		4'-8"	2'-3"	31'-0"	6'-1"
11'-0"		4'-10"	2'-4"	32'-0"	6'-4"
11'-6"		5'-0"	2'-5"	33'-0"	6'-7"
12'-0"		5'-3"	2'-6"	34'-0"	6'-9"
12'-6"		5'-5"	2'-7"	35'-0"	6'-11"
13'-0"		5'-7"	2'-9"	36'-0"	7'-1"
13'-6"		5'-9"	2'-10"	37'-0"	7'-3"
14'-0"		6'-0"	2'-11"	38'-0"	7'-5"
14'-6"		6'-2"	3'-0"	39'-0"	7'-8"
15'-0"		6'-4"	3'-1"	40'-0"	7'-10"
15'-6"		6'-7"	3'-2"	41'-0"	8'-0"
16'-0"		6'-9"	3'-3"	42'-0"	8'-2"
16'-6"		6'-11"	3'-4"	43'-0"	8'-5"
17'-0"		7'-2"	3'-6"	44'-0"	8'-7"
17'-6"		7'-4"	3'-7"	45'-0"	8'-10"
18'-0"		7'-6"	3'-8"	46'-0"	9'-0"
18'-6"		7'-8"	3'-9"	47'-0"	9'-3"
19'-0"		7'-11"	3'-10"	48'-0"	9'-5"
19'-6"		8'-1"	3'-11"	49'-0"	9'-7"
20'-0"		8'-3"	4'-1"	50'-0"	9'-9"
21'-0"		8'-8"	4'-3"		
22'-0"		9'-0"	4'-5"		
23'-0"		9'-5"	4'-7"		
24'-0"		9'-10"	4'-10"		
25'-0"		10'-2"	5'-0"		

Number of dead wraps per cable - 1 1/2 Minimum (with car on buffer or pit floor)

Use the above chart to determine the distance between the winding drum and the first deflection sheave based on total car travel. The distance shown is the minimum. If more space is available, use it.

# EXAMPLES OF TYPICAL INSTALLATIONS MAY BE FOUND ON THE NEXT FEW PAGES FOR YOUR GUIDANCE.

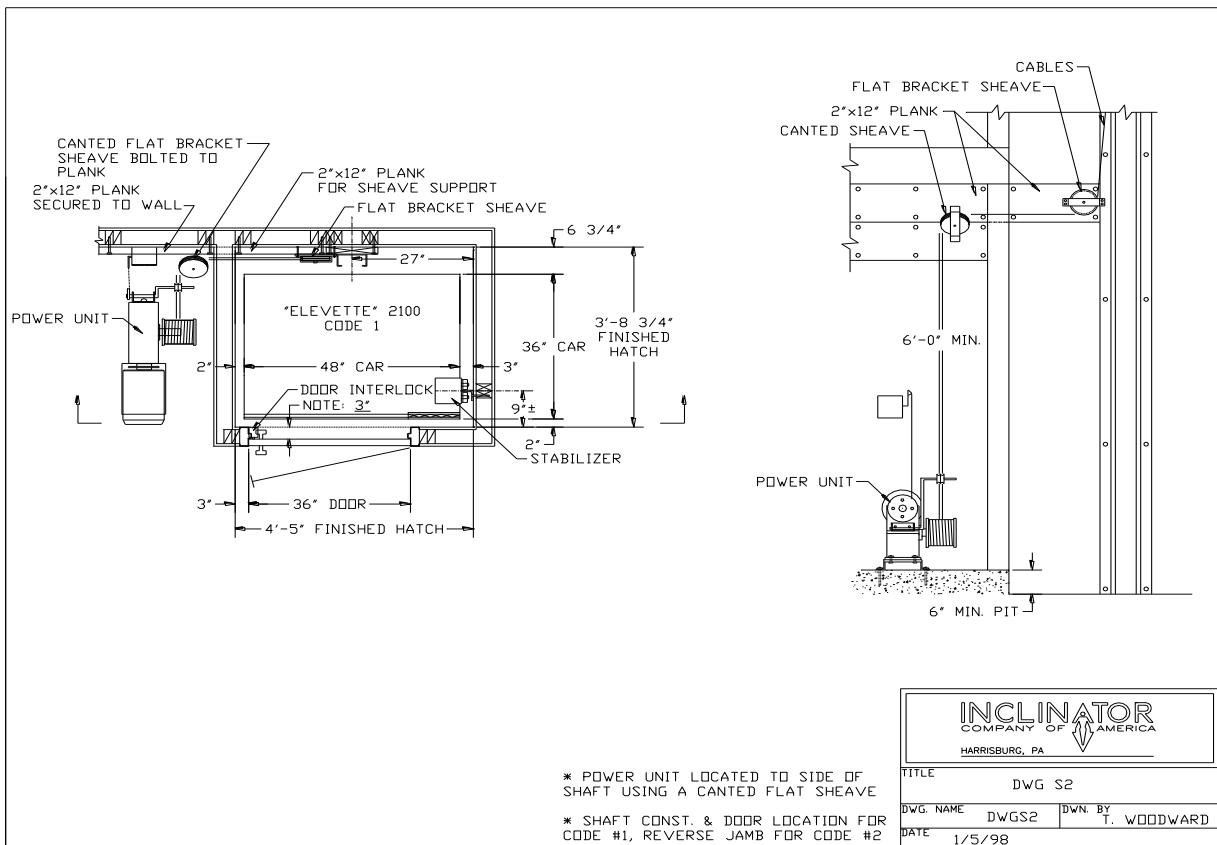
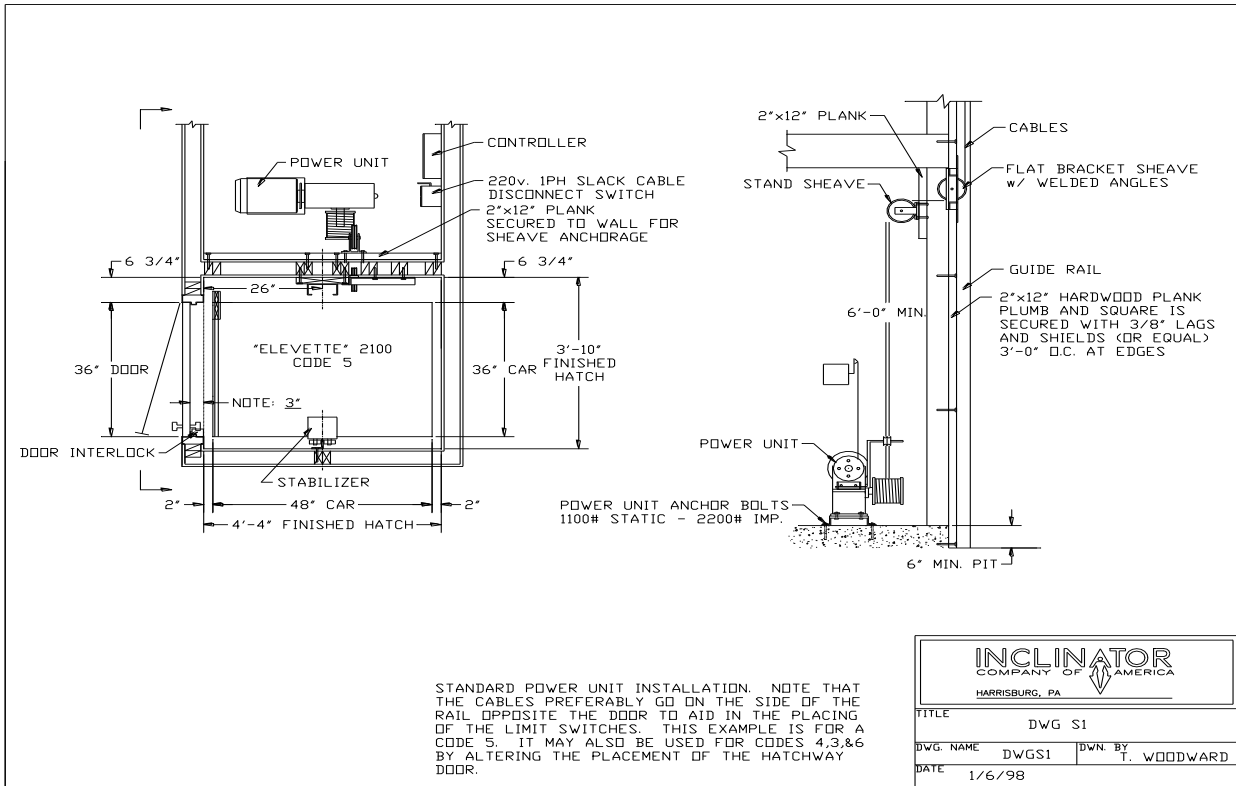

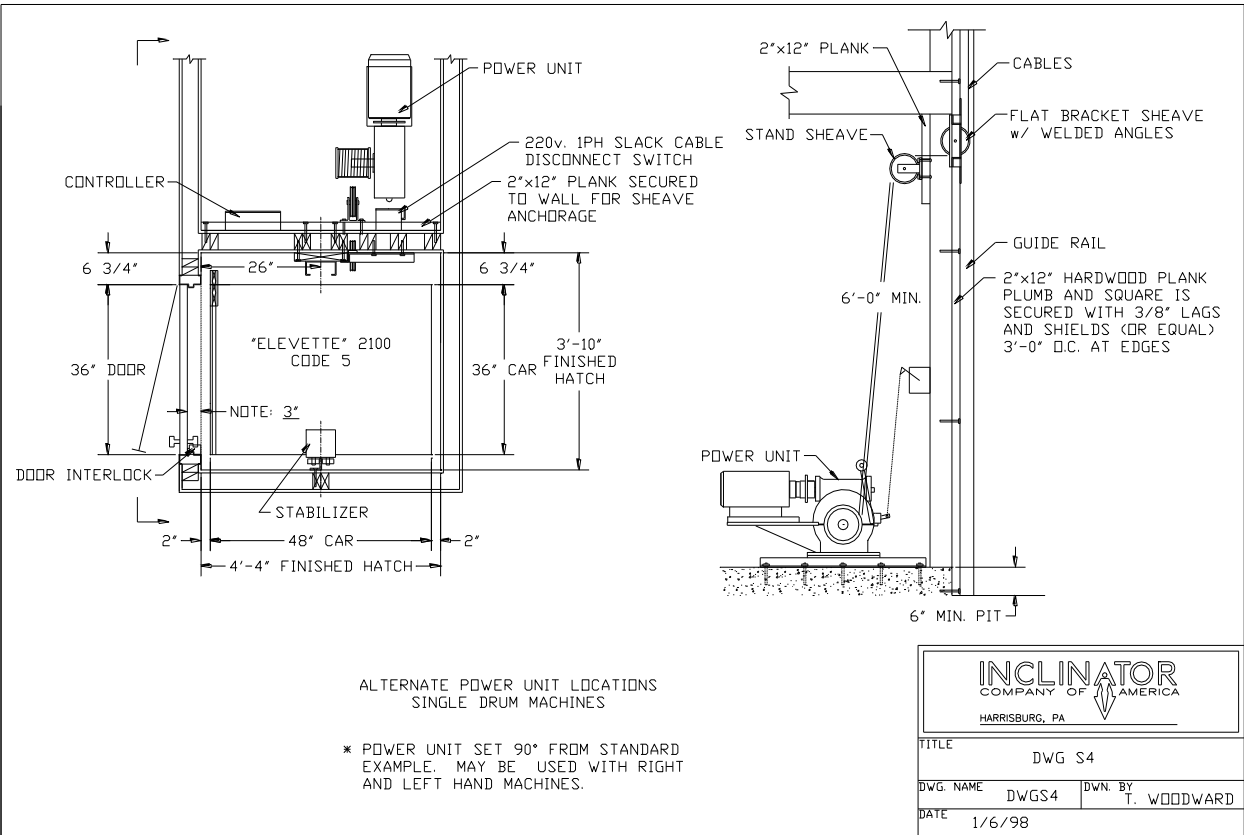
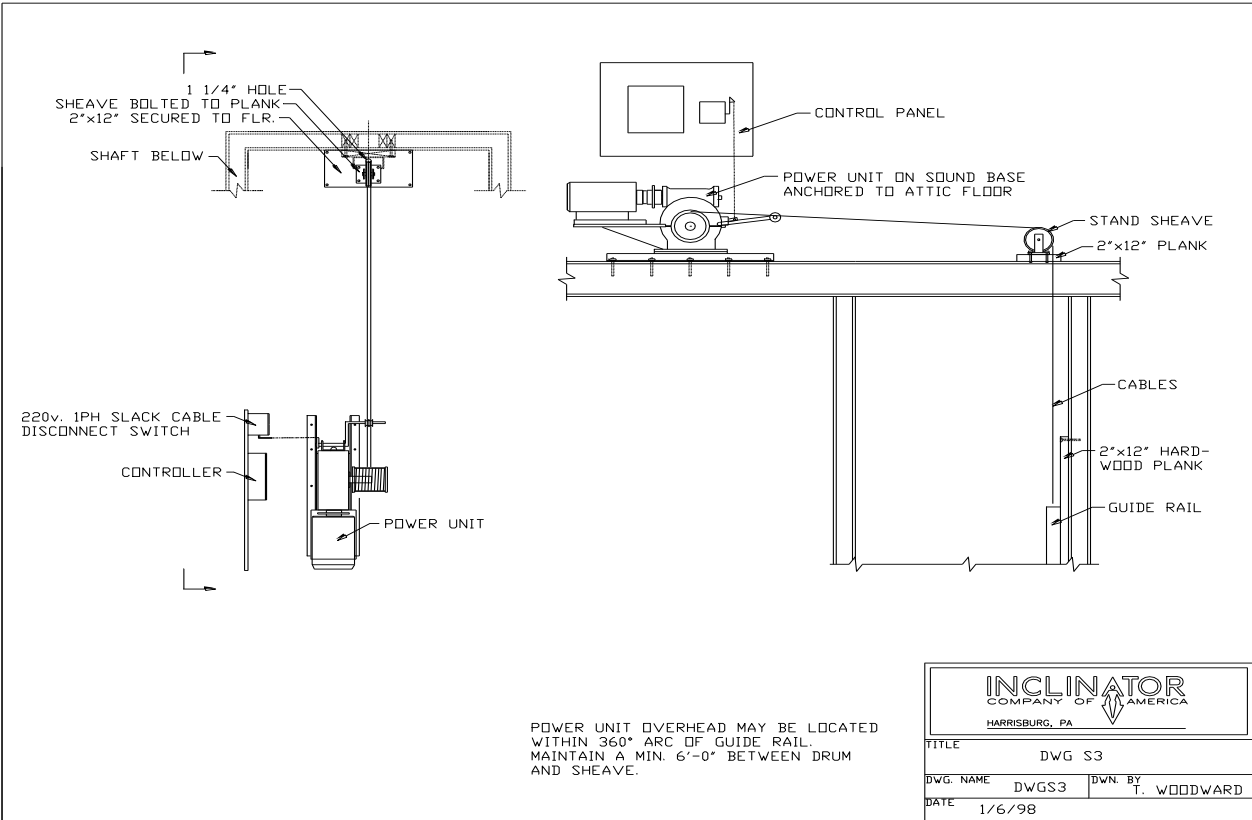

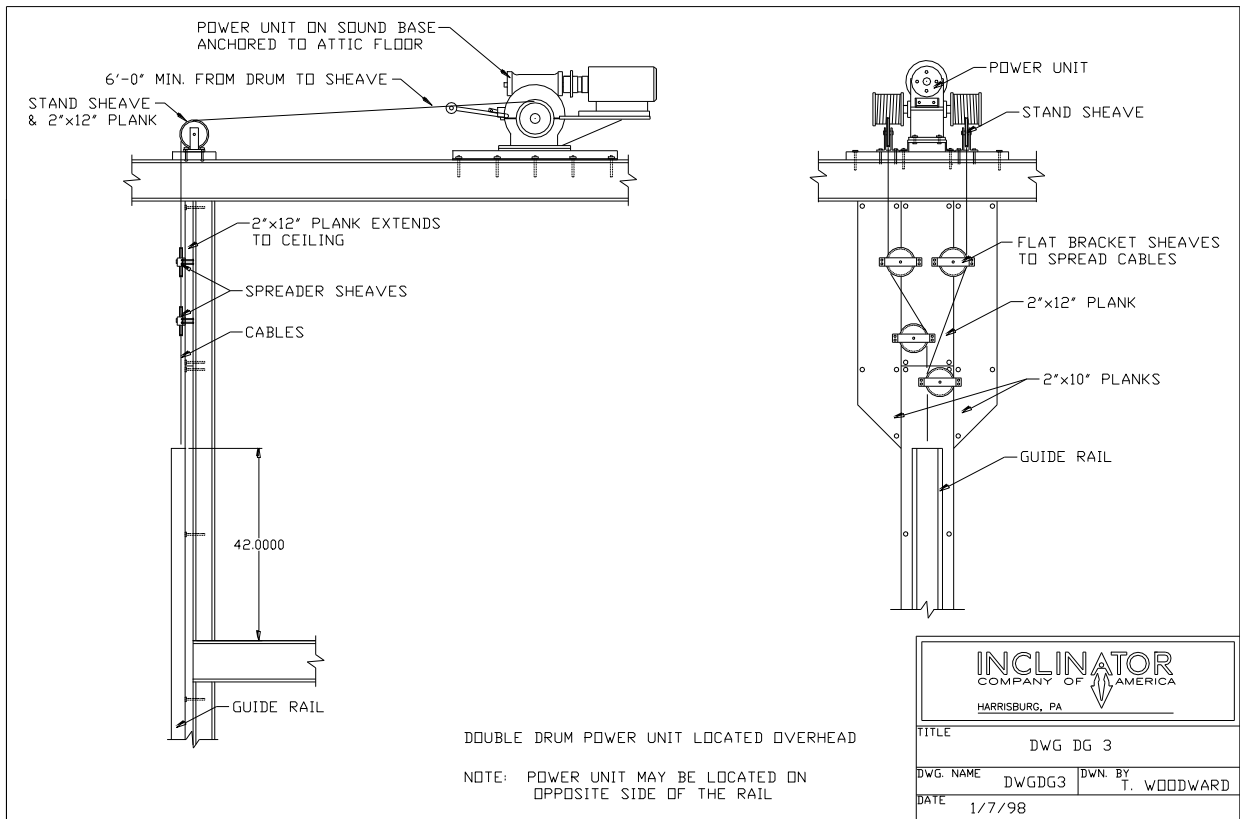
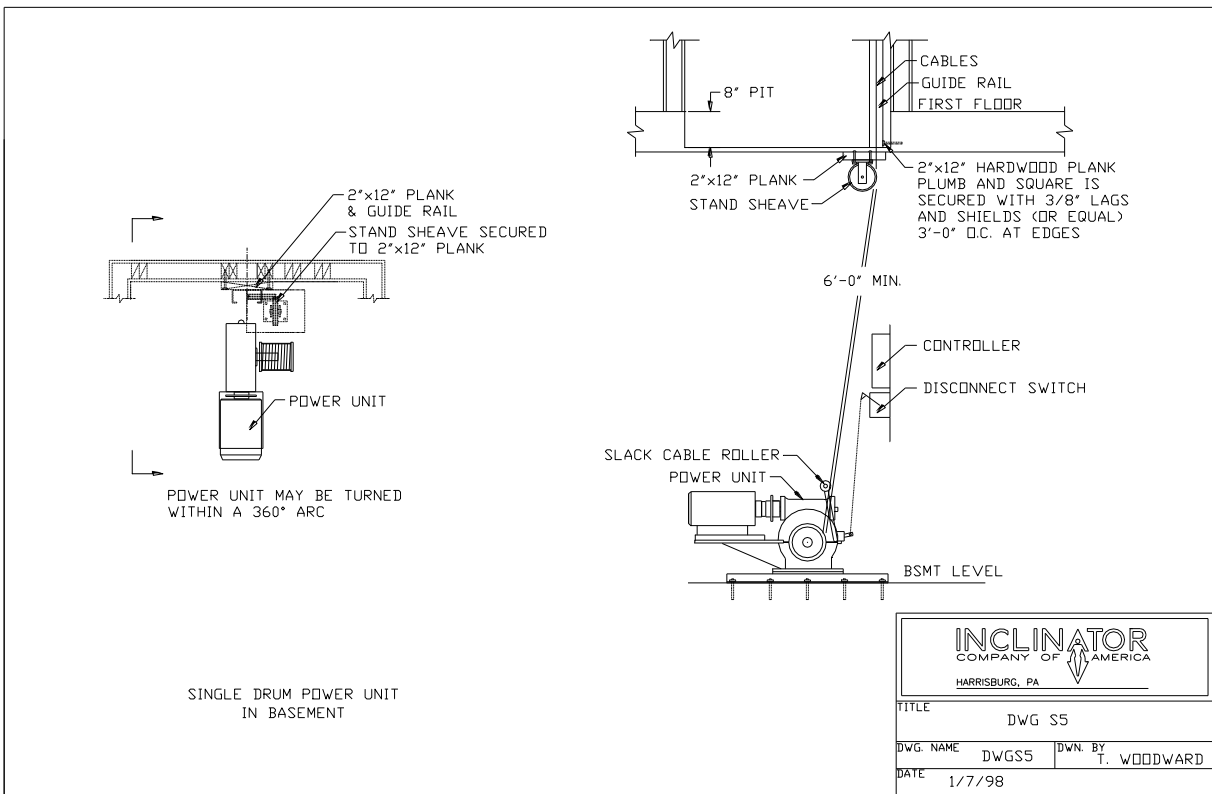



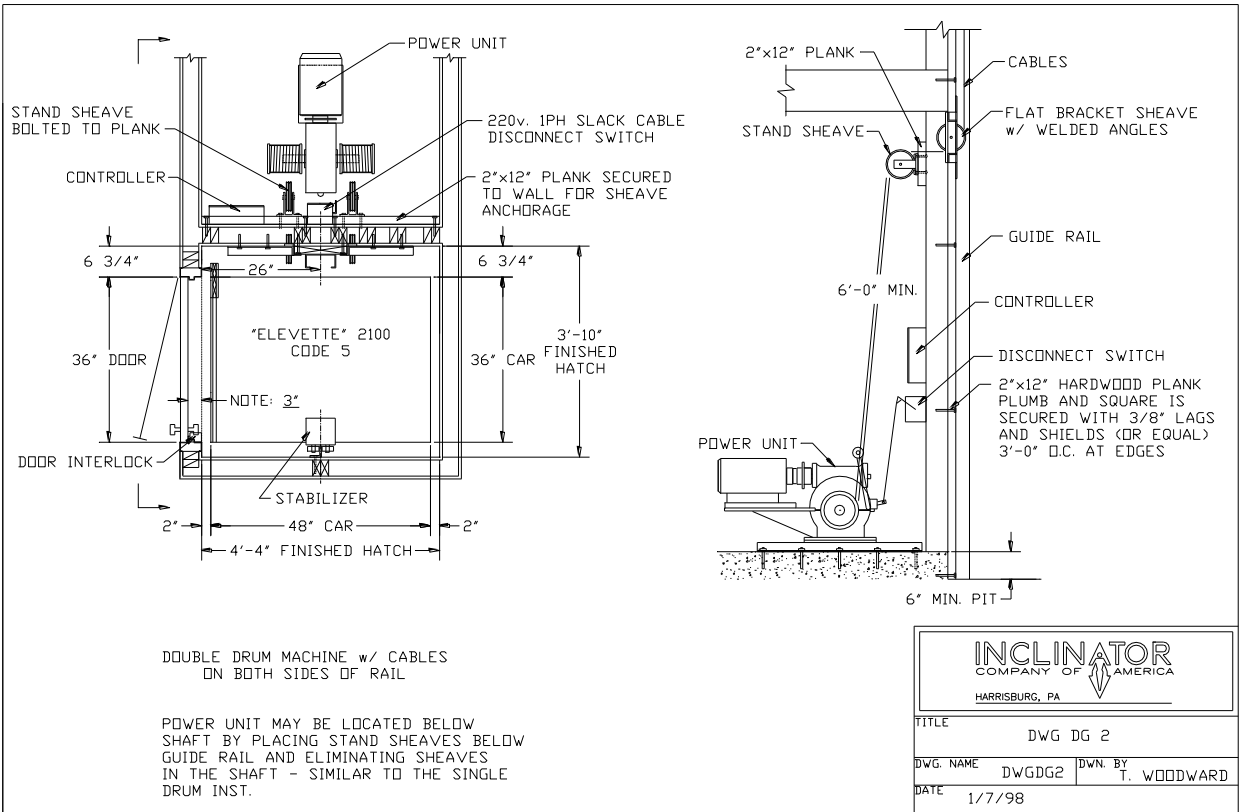

# PLACEMENT OF CENTER OF PLANK AND FLAT BRACKET W/ANGLE SHEAVES

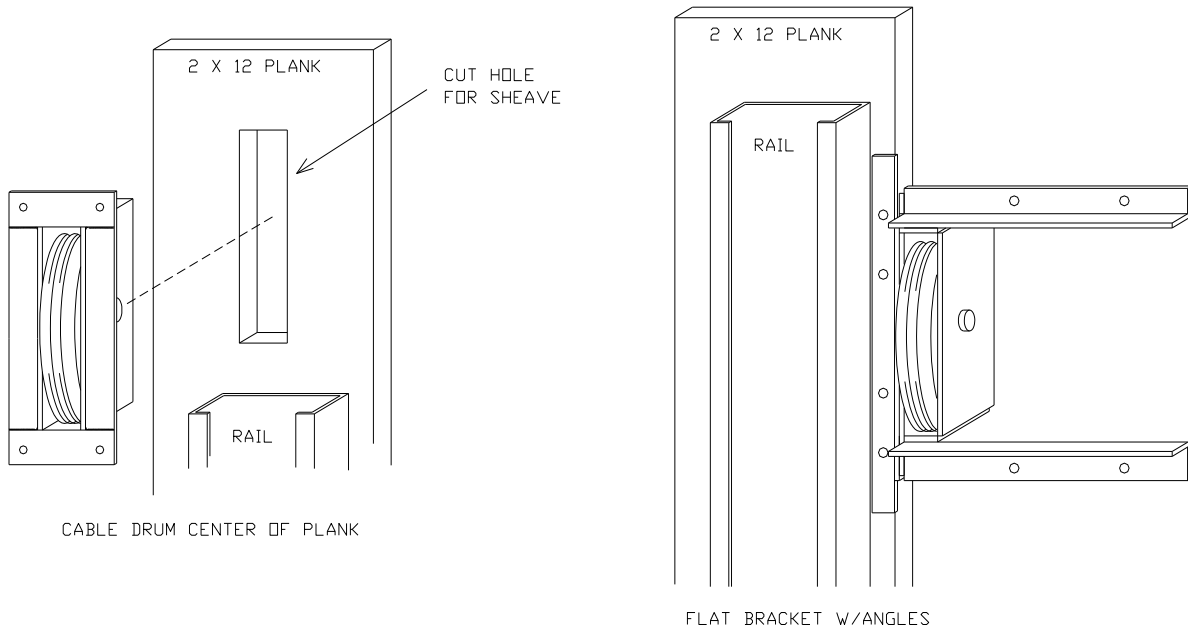

## THREADING SUSPENSION CABLES

1. If the suspension ropes are not installed through the trolley, carefully un-wrap each length of cable. One end of each cable will have a swaged fitting and the other cable end will be fuse cut.
2. Position the trolley assembly at the bottom of the guide rail or against the physical stop (if supplied), see drawing below.
3. Take the fuse cut end of the rope and at the trolley thread through the safety dog link arm, the upper axle on the trolley plate and then through the loose axle above the trolley plate assembly. Do this for both cables.
4. Use a C-clamp or similar device to secure the trolley in position when roping.
5. Thread cables around sheaves, then to machine room. Be sure you have proper fleet angle ( $1\frac{1}{2}$  degrees) and make sure cables ride in sheave grooves. Wind cables onto drums making certain they are in the grooves for at least  $1\frac{1}{2}$  wraps.  $1\frac{1}{2}$  wraps is the minimum amount of cable that should be left on the drums with the trolley at the bottom of the shaft. Both cables must be tensioned evenly before cable lugs are placed on the ends. When cables are threaded and tensioning is even, tighten the lugs using a  $\frac{5}{32}$ " Allen wrench. Mark the excess cables 12" after the lug and tape tightly with electrical tape. Then cut the cables and stuff the remaining 12" into the end of the drum.



### CAUTION

**FAILURE TO MAINTAIN AT LEAST  $1\frac{1}{2}$  TURNS OF CABLE ON THE DRUM WHEN THE ELEVATOR IS AT THE BOTTOM OF IT'S TRAVEL MAY RESULT IN INJURY OR DEATH.**

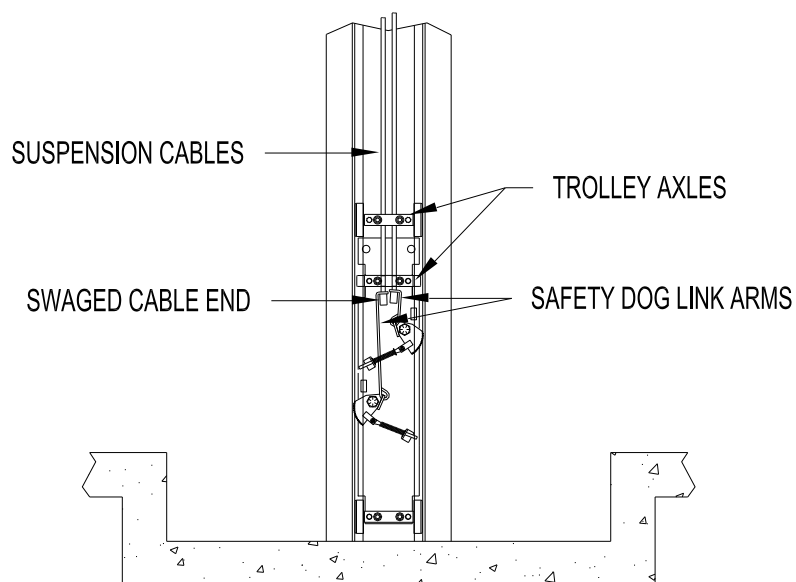

## INSTALLING CAR BASE

1. Separate the steel car base frame from the car by removing the hex head lag screws that hold the car floor to the steel pan along with any Phillips head wood screws that go through the steel pan along the rear wall of the car. These fasteners will be re-used when installing the car.
2. Move the steel base into the hoistway and align the 3 x 3 stem with the guide rail. Using two (2) of the  $\frac{1}{2}$ " x 4" long flat Head bolts supplied, attach the top axle to the base stem through the top two holes in the stem. Do not tighten at this time.
3. Use the 2<sup>nd</sup> set of flat head bolts to attach the upper axle on the trolley plate to the middle set of holes in the base stem. Do not tighten at this time.
4. Raise the base high enough to gain access to the mounting holes at the bottom of the stem. Use two (2)  $\frac{1}{2}$ " x 4" Socket Hd. Cap screws secure the bottom trolley axle to the base. Tighten these bolts, then securely tighten the other four (4) bolts.

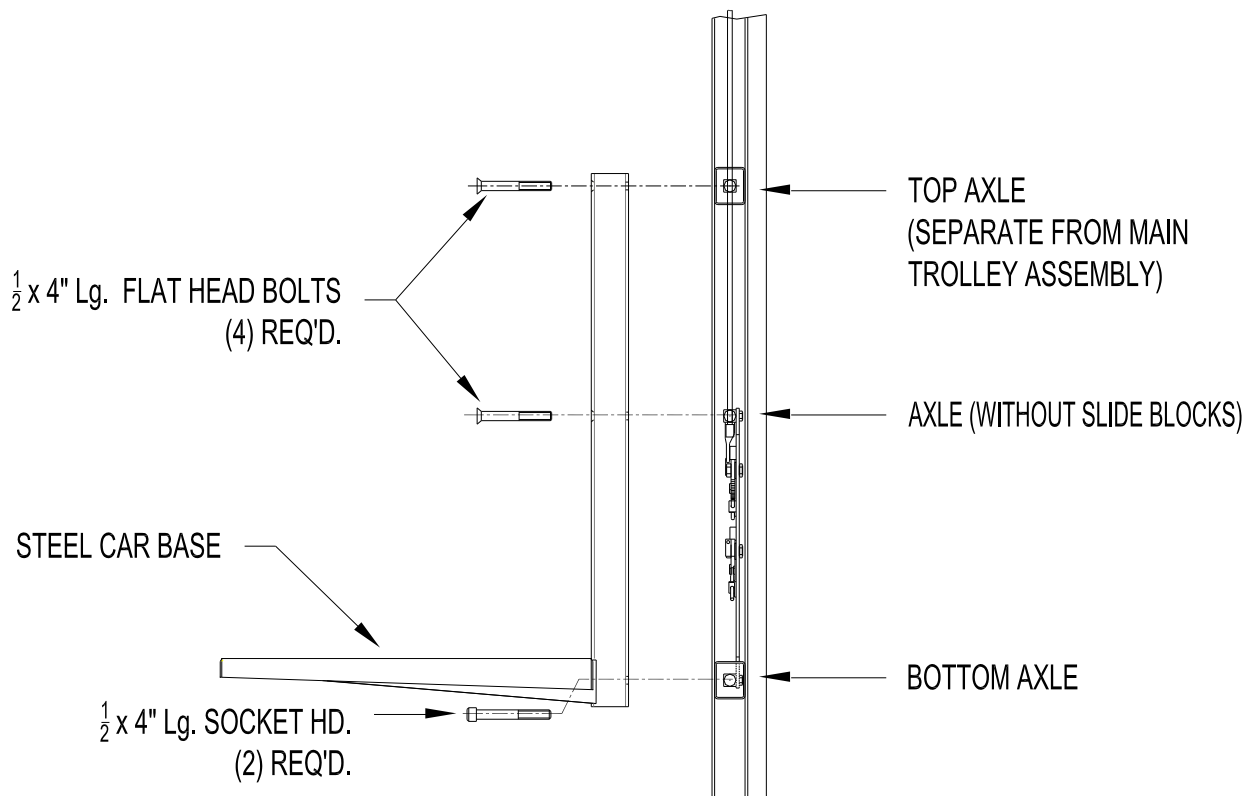

SIDE ELEVATION VIEW OF GUIDE RAIL

## LUBRICATING GUIDE RAIL

Lubricate front and back of guide rail, where the slide blocks travel, with (NYLUBE) **Rail Lube**. Wipe rail clean before applying.

## INSTALLING WOOD CAB

### NOTE:

- **If Car is shipped assembled, do not disassemble car until car is ready to be installed.**
- Remove Gate Header attached to the side of the car for shipping.
- When car is installed fasten the Header with the screws provided at the top of the car to cover up the edge of the gate track and plywood.

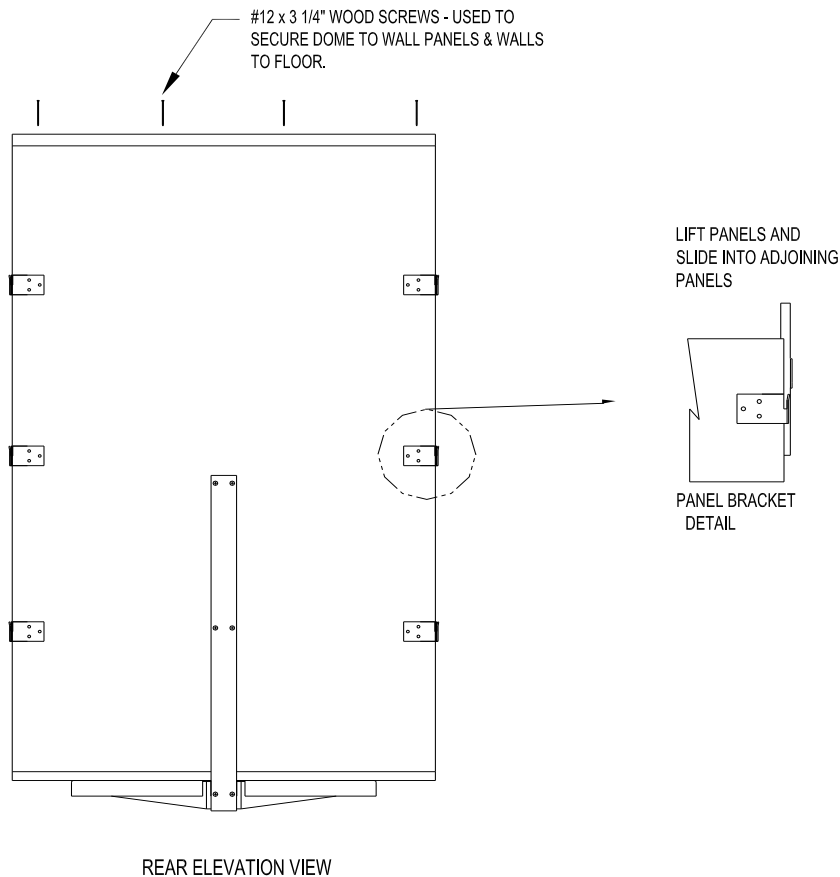

1. Install the Plywood Floorboard onto the steel base, align the holes in the underside of the floorboard with the holes in the base, then secure with the lag screws that came with the car. Run the platform from the bottom to the top floor to insure there is adequate running clearance on all sides.
2. Install rail side panel first. A clip may be provided on the back of this panel that sets into the top of the base stem. This will help hold the panel in place. Secure with screws through the floorboard.
3. Install the adjoining panels by aligning the panel brackets above those on the fixed panel and then lower the panel so the brackets lock together. Fasten panels to floorboard with screws.
4. Install the car dome and secure with screws.

## INSTALLING 500 STYLE CAB

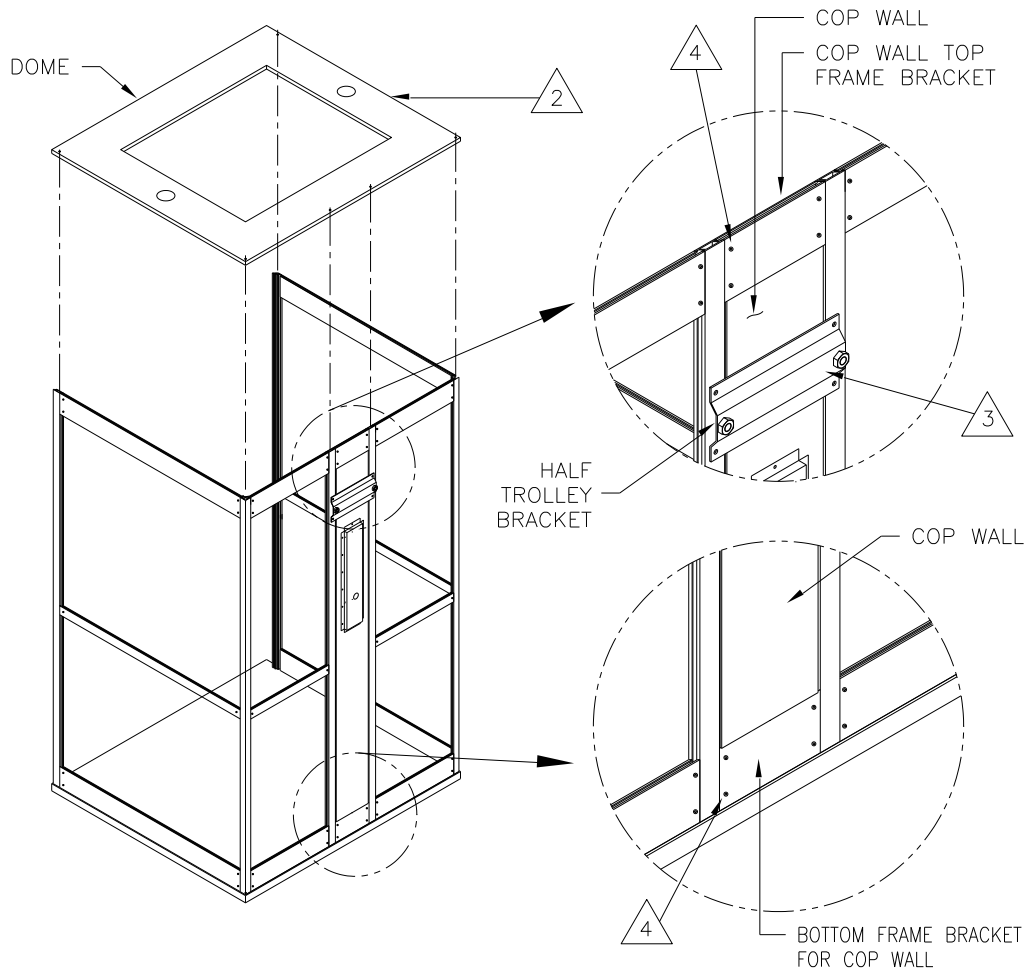

### 500 Cab DISASSEMBLY INSTRUCTIONS:

1. If a steel base is attached to the cab floor, remove it. If gates are installed, remove them.
2. Separate the dome from the cab walls by removing the  $\frac{1}{4}$ -20 x  $1\frac{3}{4}$ " Lg. Hex Hd. bolts and flat washers along the perimeter of the dome.
3. If installed, remove the half trolley bracket from the cab wall by removing the four (4)  $\frac{1}{2}$ -20 x  $\frac{3}{4}$ " Lg. Hex Hd. Bolts located at each corner of bracket.
4. Using a 5mm (Allen) wrench, loosen the four (4) set screws in each frame bracket above and below the COP wall of the cab. Turn each set screw  $1\frac{1}{2}$  TO 2 turns CCW.

(Disassembly instructions continued on next page.)

## INSTALLING 500 STYLE CAB (CONT.)

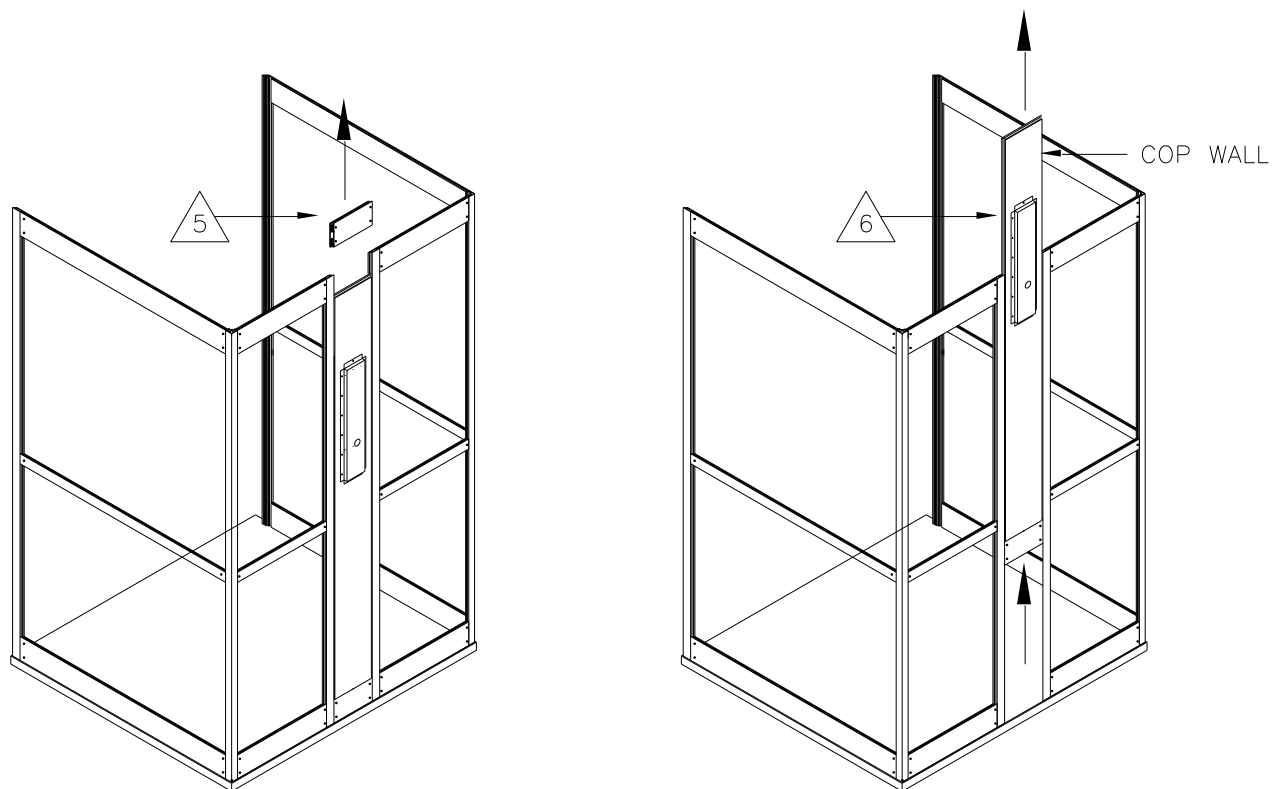

5. Remove the COP wall top frame bracket. If necessary, place a wood block on the bottom edge of the bracket and tap lightly with a hammer to separate the bracket from the COP wall.
6. Remove the COP wall along with the bottom frame bracket from the cab wall by pulling upward on the COP wall and/or pushing up on the bottom frame bracket.
7. Separate the remaining cab walls from the floor board by removing the  $\frac{1}{4}$ -20 x 2" Lg. Hex Hd. Bolts and flat washers located along the perimeter of the floor. **DO NOT ATTEMPT TO DISASSEMBLE THE WALL SECTIONS ANY FURTHER.**

## INSTALLING 500 STYLE CAB (CONT.)

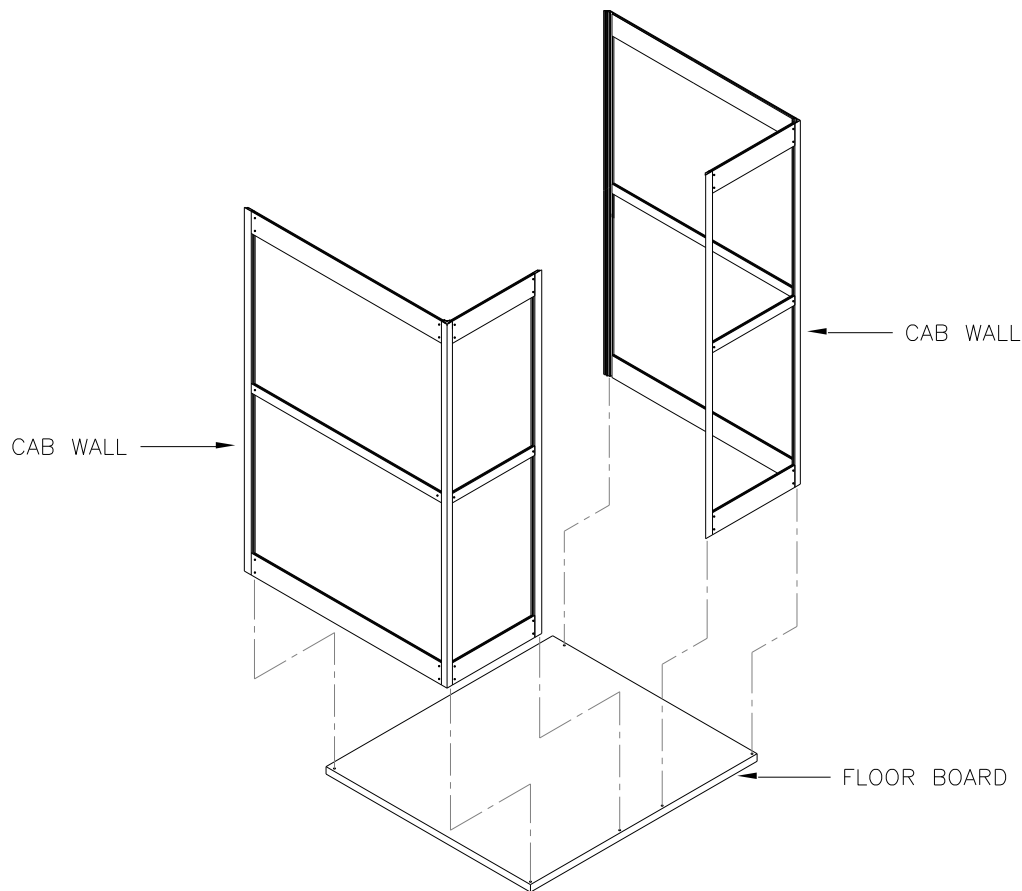

### 500 Cab Assembly Instructions

1. With the cab floor board secured to the cab platform frame, move the wall assemblies into the shaft and set on the cab floor.
2. Position each wall on the cab floor and secure with the  $\frac{1}{4}$ -20 x 2" lg. bolts and flat washers, but do not tighten at this time.
3. Re-install COP wall then tighten all set screws in the bottom and top frame brackets. Be certain the top frame bracket is flush with the walls. Tighten all bolts holding walls to floor.
4. Re-install half-trolley bracket if part of assembly.
5. Set dome on top of walls and secure with  $\frac{1}{4}$ -20 x 1  $\frac{3}{4}$ " Hex Hd. Bolts and flat washers.



- Assemble gate(s) onto cab.

## TOE GUARD INSTALLATION

A toe guard (one per car gate) is supplied and must be installed if the auto-leveling feature is enabled. There are two rows of mounting holes in the toe guard but only one row is used depending on the type of gate installed on the elevator (see drawing below). When installed, the toe guard must be positioned below the car floor so it extends across the full width of the hoistway door opening.

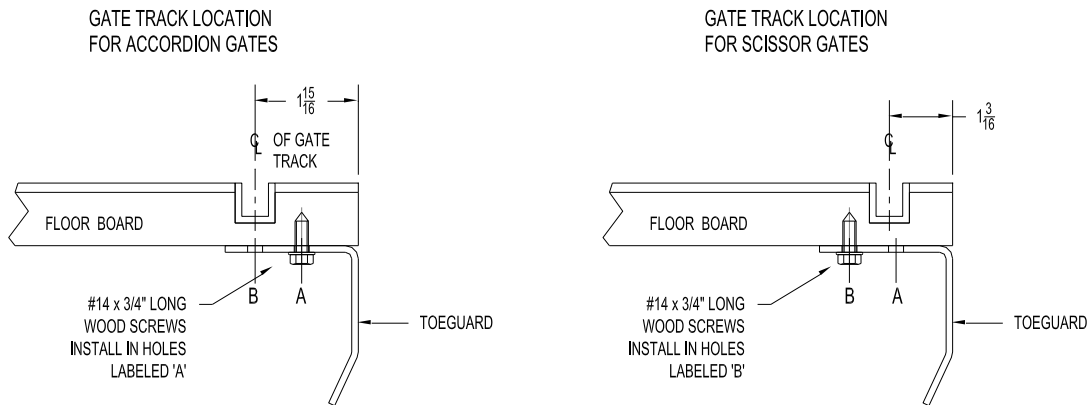

## STABILIZER RAIL INSTALLATION (OPTIONAL)

A car stabilizer rail and roller assembly is available for the purpose of steadying the elevator car. The parts include a 2 x 2 steel angle, a three-roller bracket assembly (A3) and a two-roller bracket assembly (A2). Hardware is supplied for mounting the angle to the hoistway wall and the roller assemblies to the car.

- On all cars except codes 1 & 2 the stabilizer angle should be located opposite the main guide rail. If available, refer to shop drawings for location. **A minimum running clearance of 3 inches is required between the car and finished hoistway wall for mounting the rail.** The rail should be backed double 2x4 studs (or a 4 x 4) from bottom to top.
- The angle is typically supplied in sections that are bolted together. Each section end is numbered and should be joined with another section with the same number.
- Start installation at the pit and work up. Secure angle to wall using 1/4" x 2" lag screws provided by factory. The angle must be installed plumb and run parallel to the main guide rail.
- Attach the A3 roller assembly to the car top using (3) 1/4" x 3/4" hex head wood screws. Attach the A2 roller assembly to the car bottom using (3) #12 x 1" wood

screws. **Holes must be drilled in each bracket for securing to car with screws.**

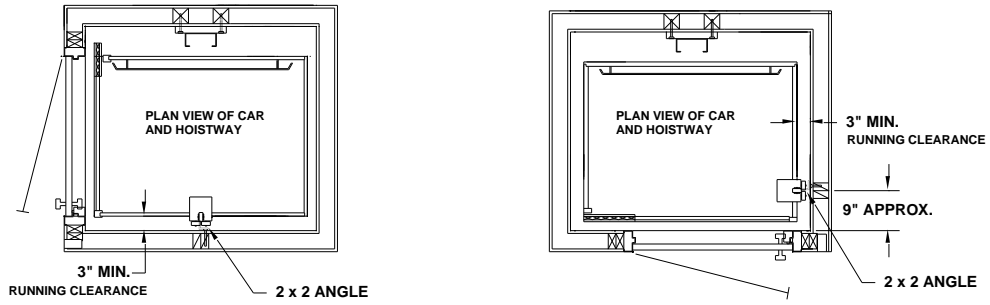

**STABILIZER ASSEMBLY**

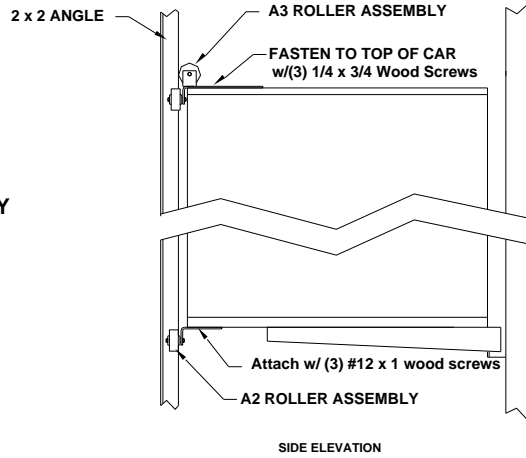

## INSTALLING CAR HALF TROLLEY (OPTIONAL)

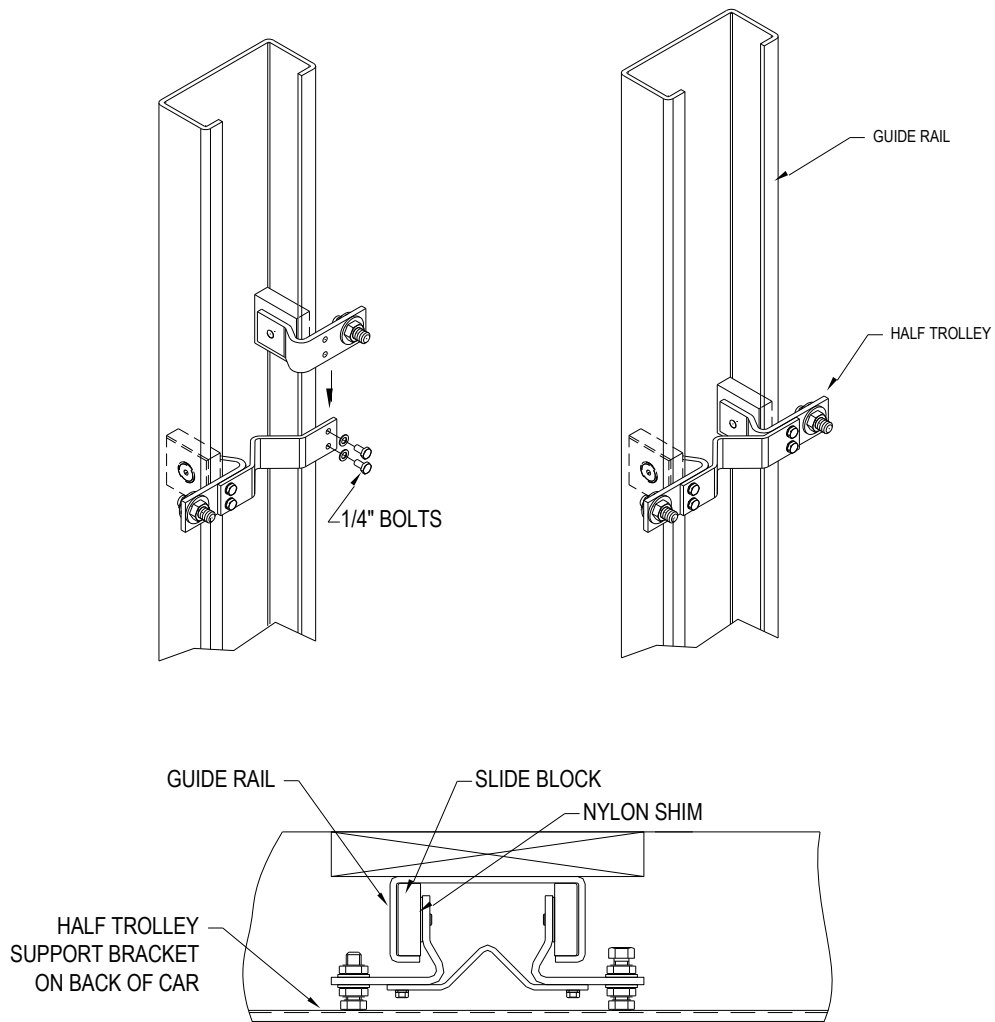

### INSTALLATION INSTRUCTIONS:

1. SEPARATE ONE SIDE OF THE HALF TROLLEY BY REMOVING TWO  $\frac{1}{4}$ " BOLTS AS SHOWN.
2. ABOVE THE CAR, POSITION BOTH SLIDE BLOCKS INSIDE THE GUIDE RAIL, THEN REASSEMBLE AND TIGHTEN  $\frac{1}{4}$ " BOLTS.
3. SLIDE THE ASSEMBLY THROUGH THE RAIL TO CHECK FIT. IF THE SLIDE BLOCKS ARE TOO TIGHT INSIDE THE RAIL, DISASSEMBLE AND REMOVE A NYLON SHIM FROM BEHIND ONE OF THE SLIDE BLOCKS.
4. LOOSEN THE NUTS ON THE HALF TROLLEY THEN SCREW THE  $\frac{1}{2}$ " BOLTS ONTO THE CAR SUPPORT BRACKET. RE-TIGHTEN THE NUTS AGAINST THE HALF TROLLEY BRACKET TO LOCK THE BOLTS IN PLACE.

# MOUNTING THE STEEL TAPE & THE TAPE READER GEN III

Reference drawing 80211227, Tape Reader Installation.

1. Unpack all the Tape Reader System parts and verify against the installation drawing.
2. Decide which side of the car the Tape Reader will be mounted on. Insure that the tape reader will not be interfered with by the traveling cable or any other obstructions.
3. Refer to the installation drawing listed above for installation details.

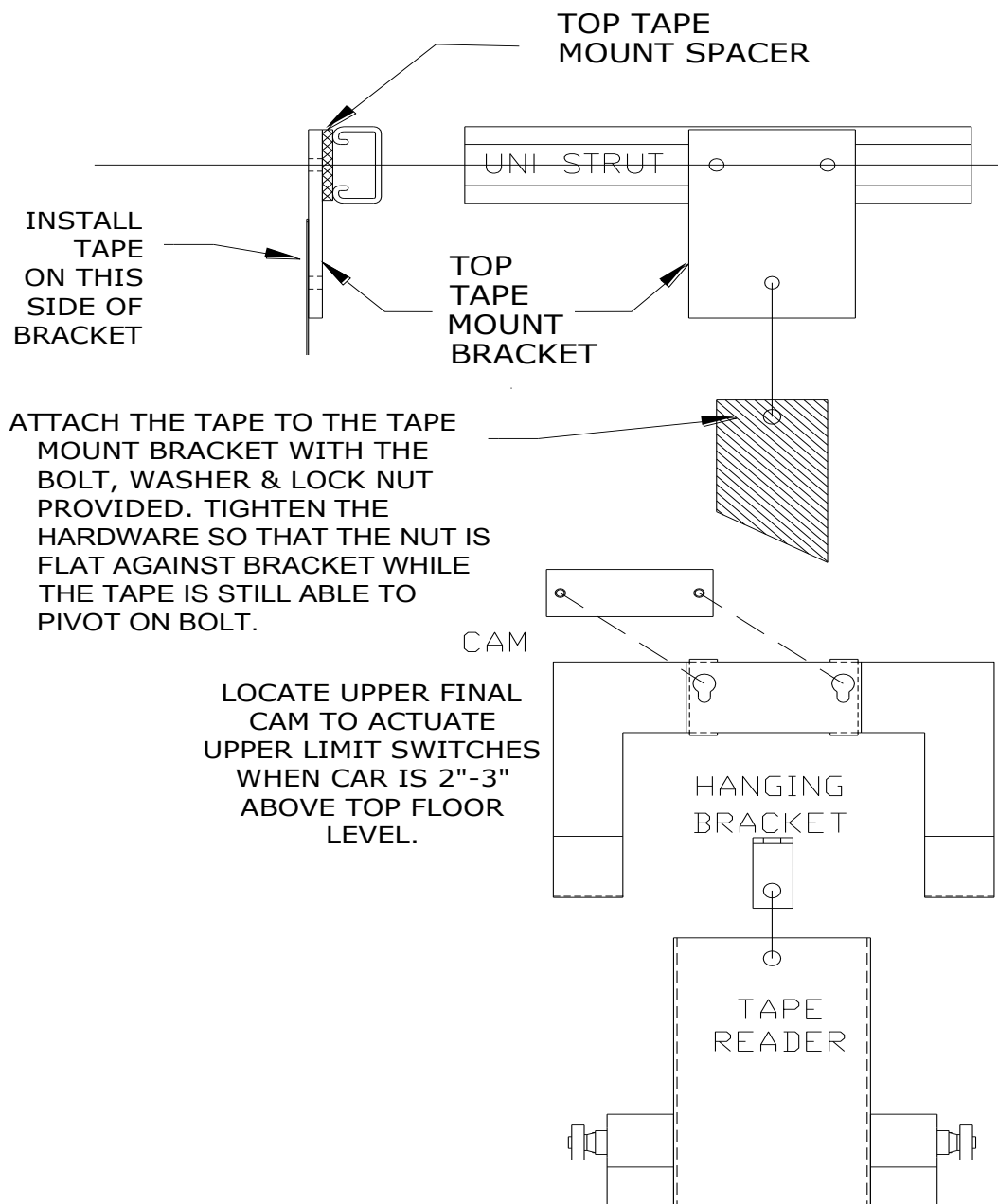

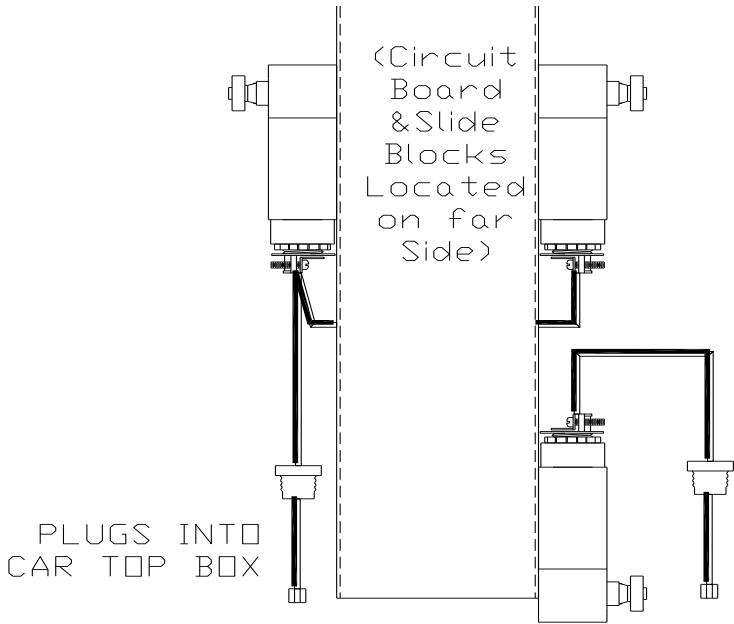

LOCATE LOWER FINAL CAM TO ACTUATE LOWER LIMIT SWITCH WHEN CAR IS 2"-3" BELOW BOTTOM FLOOR LEVEL.

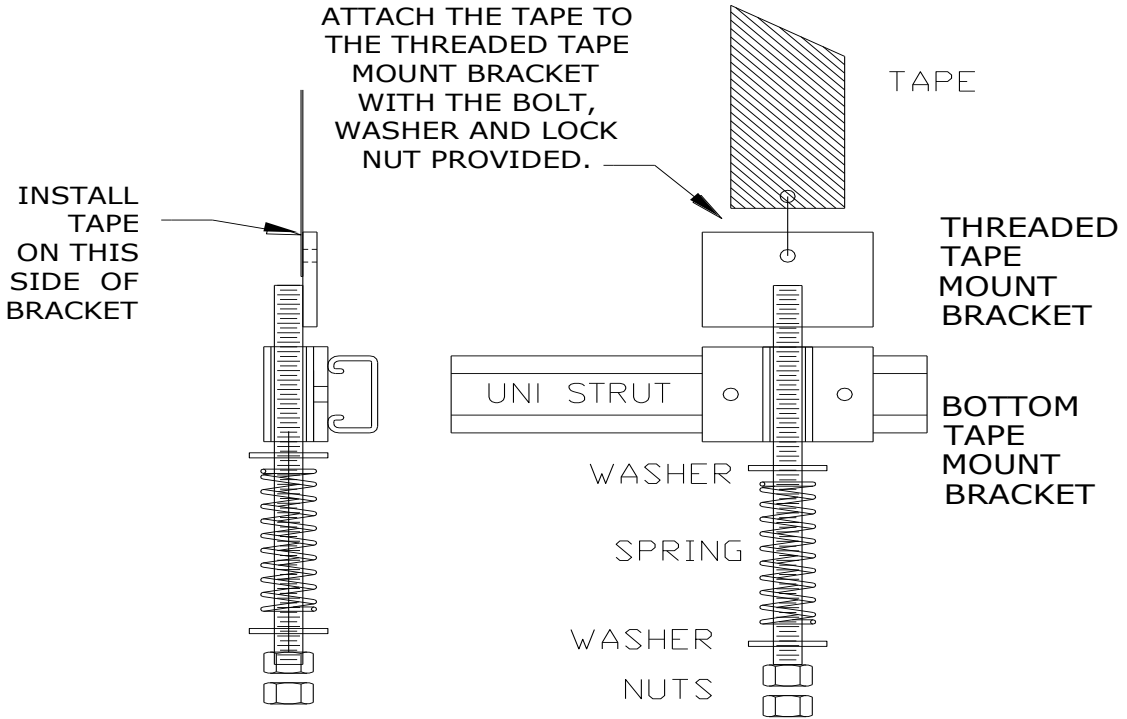
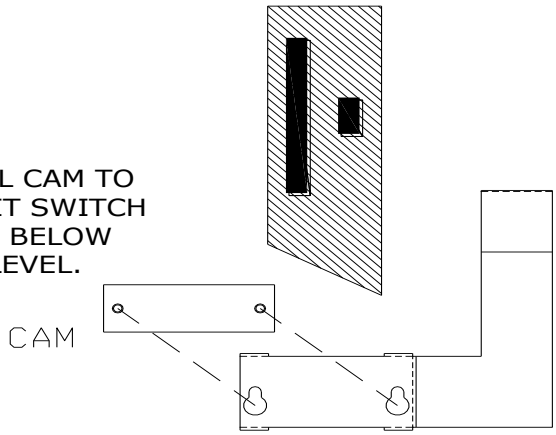

## INSTALLATION OF ELECTRICAL COMPONENTS

Refer to Inclinator's Electrical installation instructions for electrical component installation including the two controller boxes, top of car box, traveling cable, remote plates, primary disconnects and secondary disconnects. Refer to any national, state and/or local codes required by the local authority having jurisdiction.



### ELECTRICAL DANGER

**Extreme caution must be taken when working around electrical circuits. There must be a reliable ground and neutral available for the elevator system in compliance with the National Electric Code. Do not use temporary power.**

### MOUNTING DISCONNECT SWITCH & CONTROLLER

Mount both a 208/240VAC and a 110VAC disconnect in the machine room. Become familiar with N.E.C. and local codes for proper wiring and clearances. Remember to run a separate ground lead.

Install a light and outlet box in the machine room as well

Become familiar with N.E.C. code procedures. Be sure to run ground lead.

### BRAKE WIRING CONNECTIONS

The brake used on the winding drum machine is DC voltage so a rectifier is required between the controller wiring and the brake. The brake rectifier is located in the motor electrical box. Refer to electrical installation instructions to make electrical connections from the controller to the rectifier.

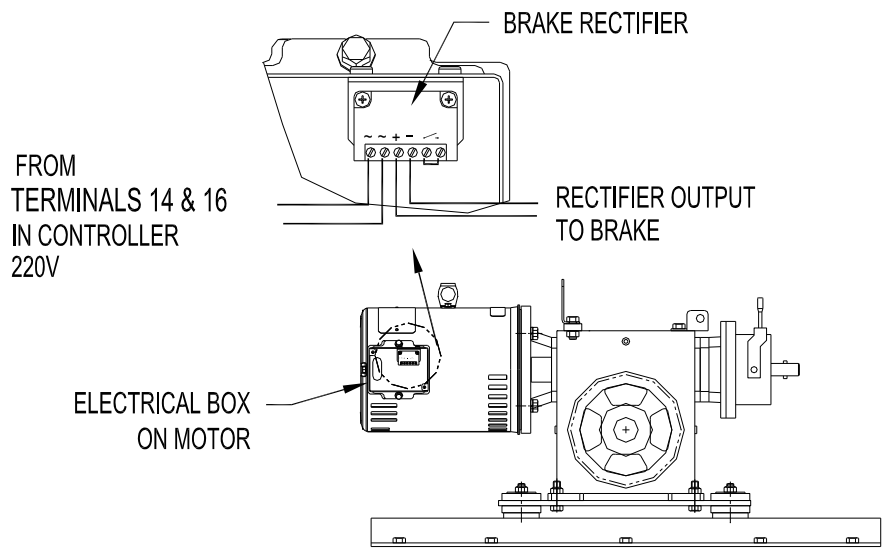

## SLACK CABLE ASSEMBLY



### CAUTION

**Improper installation of Slack Cable Assembly may result in injury or death, and/or damage to equipment.**

The Slack Cable Assembly is intended to remove power to the elevator drive in the event a suspension cable goes slack. This prevents the cables from wrapping around the drum and being destroyed. The illustration below shows a typical installation. Your installation may vary but the results should be the same. Test the Slack Cable system to make sure it functions.

1. Each Z-Iron bracket has a spring-loaded rod that maintains a constant force on the pivoting Z-Iron. Set the spring force by loosening the set screw on the pivot arm then rotate the pivot to compress the spring. Re-tighten the set screw securely.

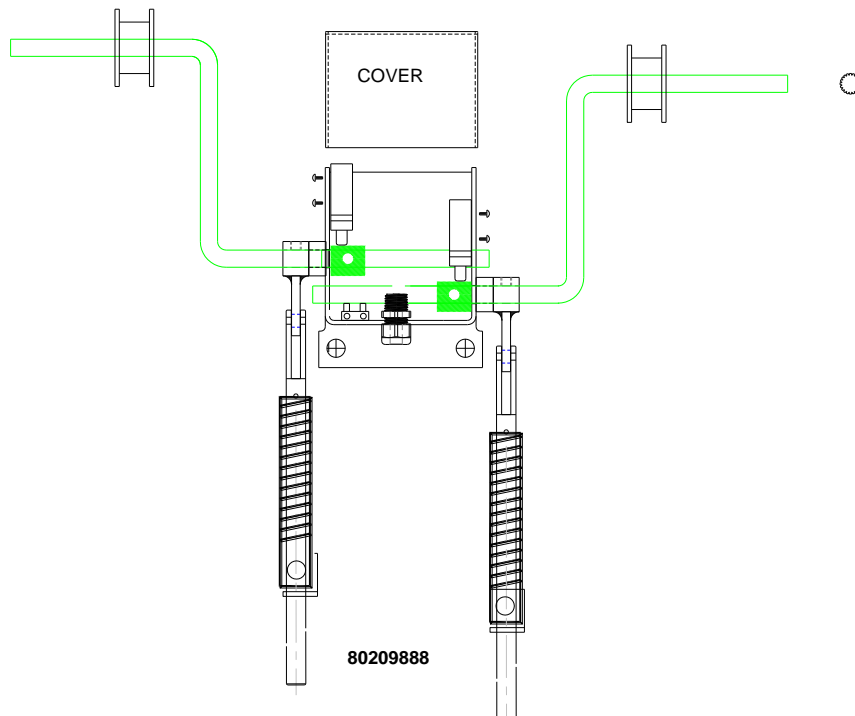

2. Refer to the drawing and assemble as shown (single drum machines will only have one side).
3. Place the roller on top of the cable with spring pressure applied to the arm, adjust the cam so the switch is in the made position (closed).
4. Connect wires from controller using cable provided.



# INSTALLATION OF LANDING DOOR FRAME OR PRE-HUNG DOOR KITS.

Inclinor manufactures optional ASME 17.1-2016 5.3 code compliant flush door frame kits and pre-hung flush door assembly kits. Installation is relatively straight forward using the information included with these kits as well as the diagram below. Contact Inclinor for more information.

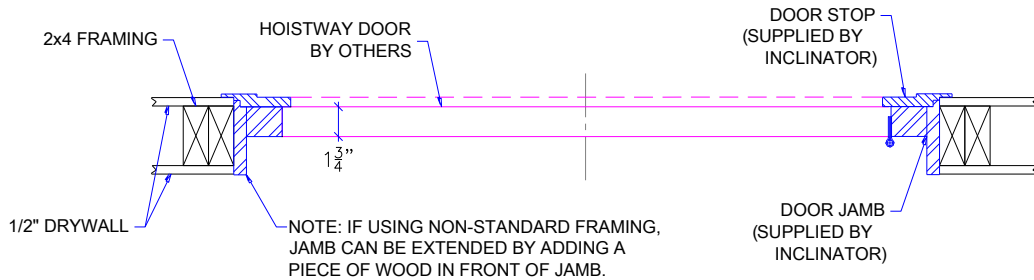

**DOOR FRAME DETAIL**  
STANDARD 2x4 CONSTRUCTION WITH  
1/2" DRYWALL (INSIDE & OUTSIDE OF HOISTWAY)

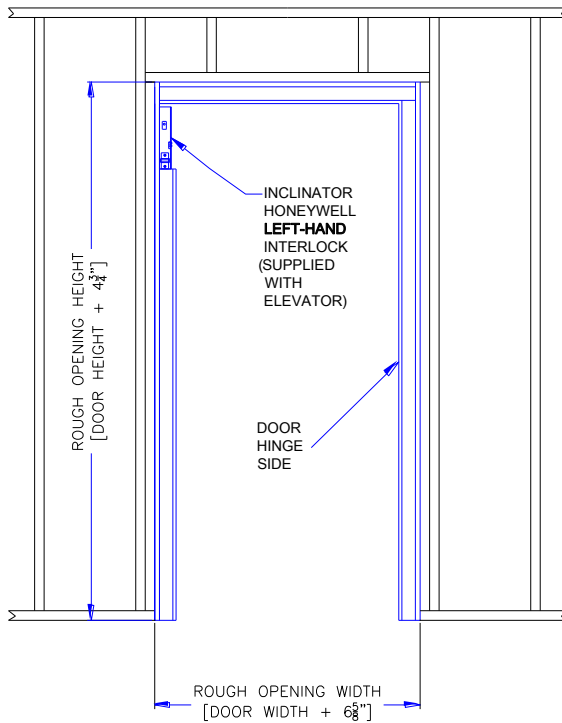

**HALLWAY VIEW**

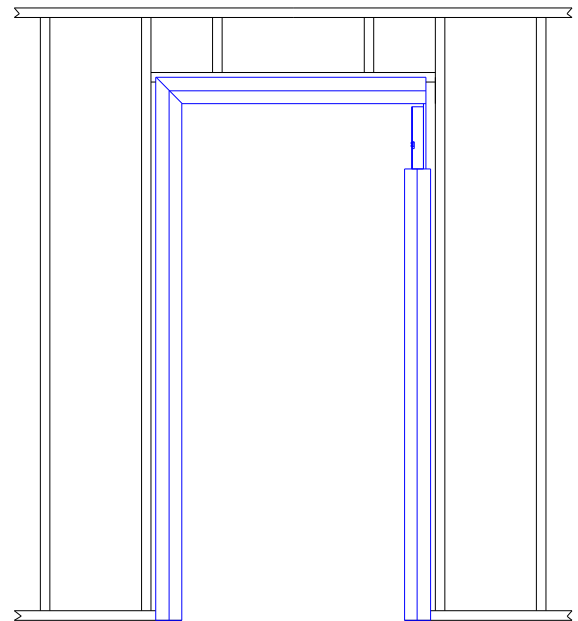

**HOISTWAY VIEW**

## INSTALLATION OF DOOR INTERLOCKS

### **WARNING**

**FAILURE TO INSTALL INTERLOCKS CORRECTLY MAY RESULT IN INJURY OR DEATH.**

### **GENERAL INFORMATION**

Inclinor-Honeywell residential door interlock switches are electromechanical devices designed for use in residential swing door applications. The interlock holds the door in place and prevents it from being opened in potentially unsafe conditions (e.g. the elevator car is not present at the landing door).

Inclinor-Honeywell interlocks comply with ANSI/ASME A17.1 & A18.1 :2010, (the safety code standards for elevator and escalators), CAN/CSAB44, and UL104 standards. The snap-action cam mechanism reduces adjustment set-up time and the key engagement was designed to minimize maintenance costs. The Inclinor-Honeywell interlocks has a robust zinc die cast housing and cover with a powder coat finish (white or bronze). Inclinor-Honeywell interlocks are available in left- and right-hand versions, allowing for simplified installation.

The Inclinor-Honeywell interlock must be specified as either “left” or “right” hand since it cannot be changed in the field. *When standing on the landing floor, looking into the elevator cab, if the lock mounts on the RIGHT side of the doorjamb it is a “RIGHT HAND LOCK”. If it mounts on the LEFT side it is a “LEFT HAND LOCK.”*

### **WARNING**

**INCLINATOR-HONEYWELL RESIDENTIAL DOOR INTERLOCKS ARE NOT A SEALED ASSEMBLIES. IT IS NOT RECOMMENDED TO BE USED IN THE AREAS WHERE LIQUID OR OIL MAY SPLASH.**

### **CAUTION**

The Inclinor-Honeywell residential door interlock is not to be used for non-residential applications where interlocking of swing type doors is required.

### **MOUNTING**

Refer to the following mounting dimension drawings for the installation locations. A separate mounting template is provided in the product packaging which will guide the installer on how to prepare for the installation of the interlock. The interlock shall be mounted only in vertical orientation with the conduit opening at the top. Remove the terminal block assembly inside the housing to reach the mounting holes. Ensure that the terminal block is assembled back onto the housing securely using the screws, once the interlock is mounted.

# LEFT-HAND MOUNTING DIMENSIONS (For reference only)

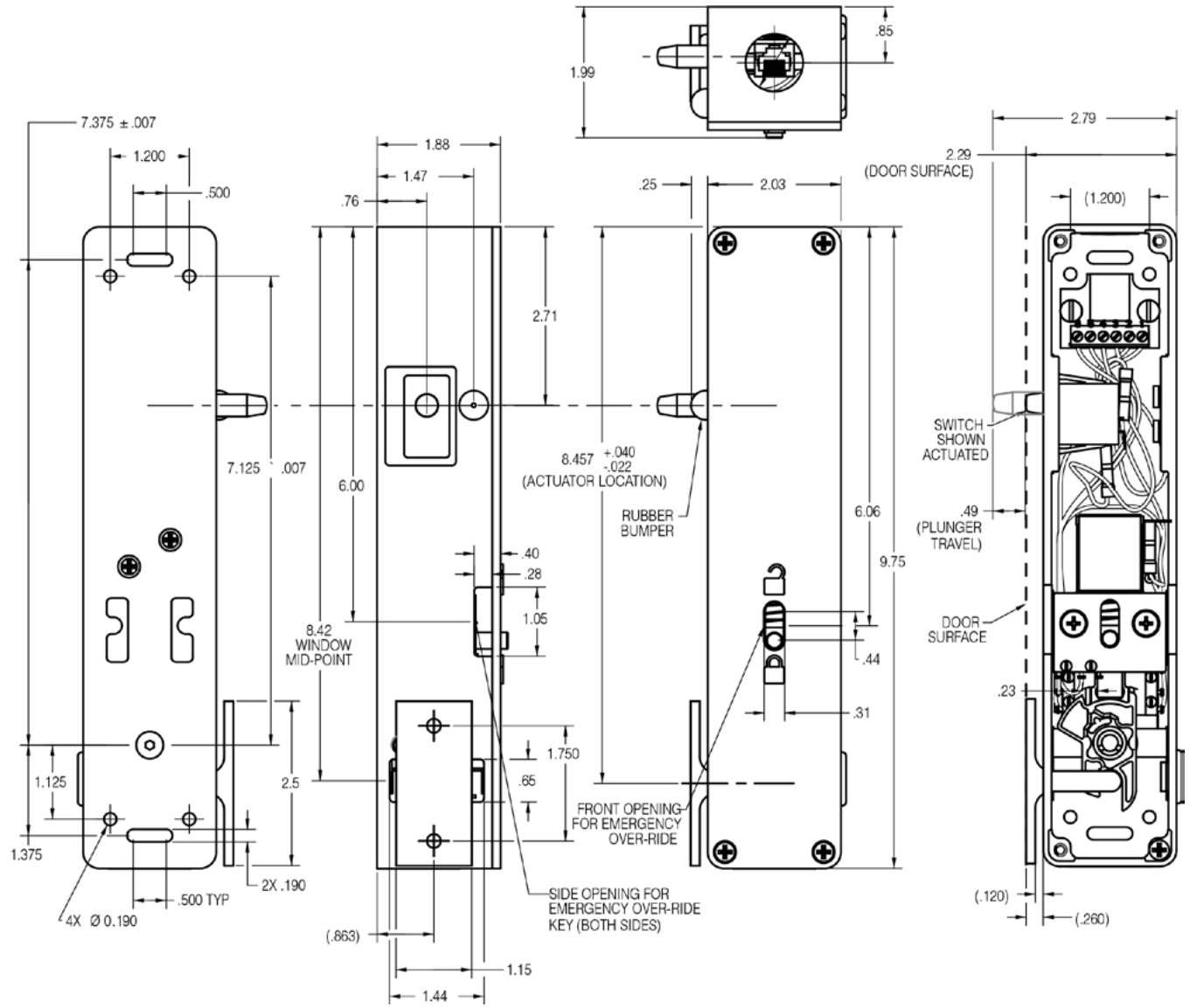

# RIGHT-HAND MOUNTING DIMENSIONS (For reference only)

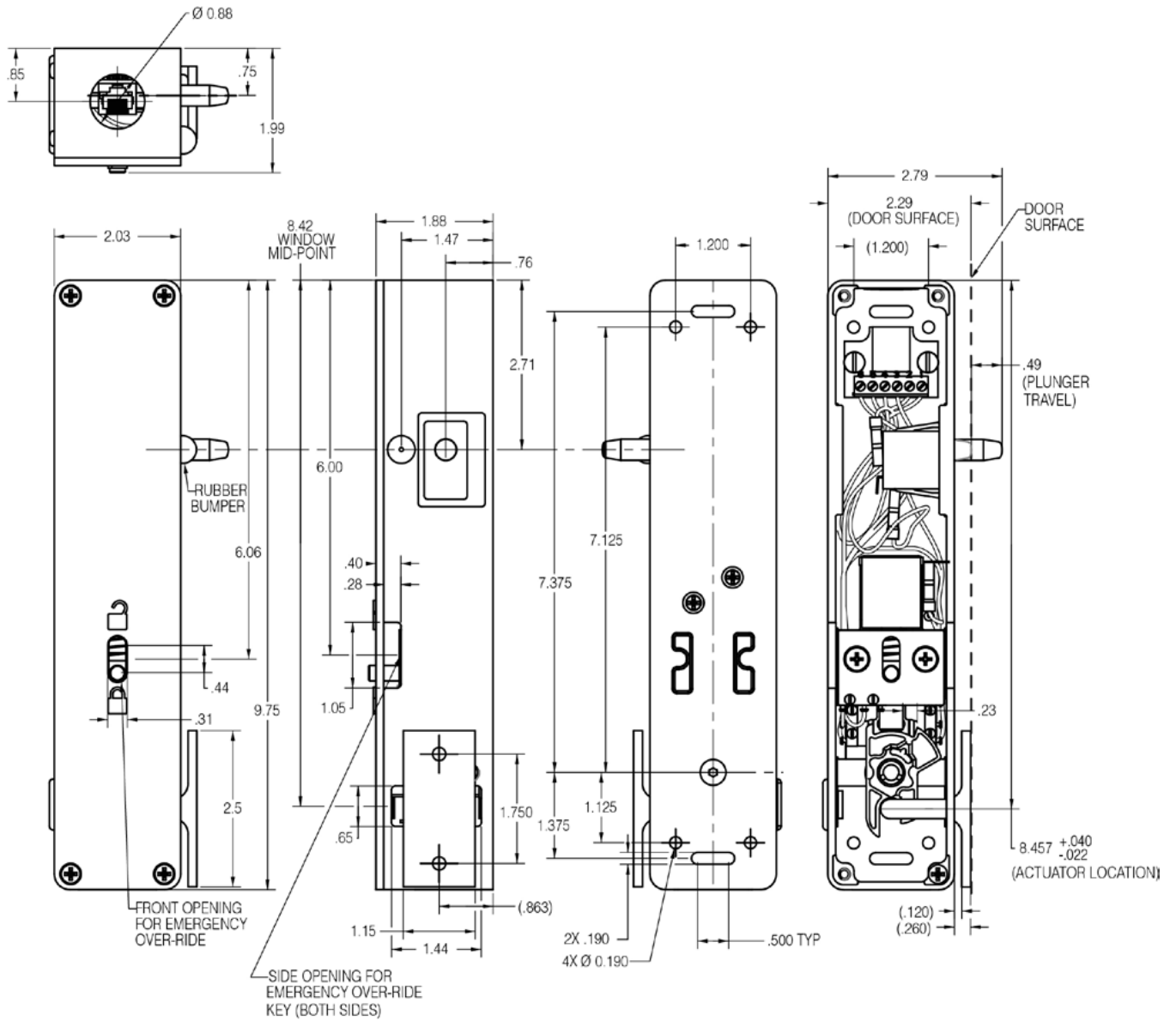

## **ADJUSTMENT**

The mounting template aligns the key to the center of the opening in the interlock housing allowing for door sag over time without any adjustment.

## **IMPORTANT NOTICE**

Strict compliance with installation instructions / mounting template is essential for safety. It is the customer's responsibility to ensure they are followed. It is imperative any wear on the actuator key or on the switch itself are identified at an early stage and the necessary corrective actions implemented (replacement), thus ensuring safety.

## **GENERAL DIRECTIONS**

- A. The actuator key for the switch **MUST** move freely without jamming during operation.
- B. The alignment of the key to the switch **MUST** be checked as per the mounting template.
- C. Visually ensure that no mechanical damage has occurred to the switch body or key. If damage is found the complete switch assembly **MUST** be replaced.
- D. Test the switch for correct electrical operation while installed and operated normally.

# INTERLOCK WIRING INSTRUCTIONS

The Inclinator-Honeywell interlock will be assembled with a wire harness designed to plug directly into the lock cable. If you need to disconnect the wire harness, use the following instruction and diagram to reconnect the harness.

1. Remove the cover by unscrewing the cover screw(s).
2. Unscrew the terminal screws. Connect wires per the schematic provided below. Torque all terminal screws with a tightening torque of 0.5 Nm to 0.7 Nm.
3. Reinstall the cover and securely tighten the screw(s). Recommended tightening torque for the cover screw(s) is 1.5 Nm max.

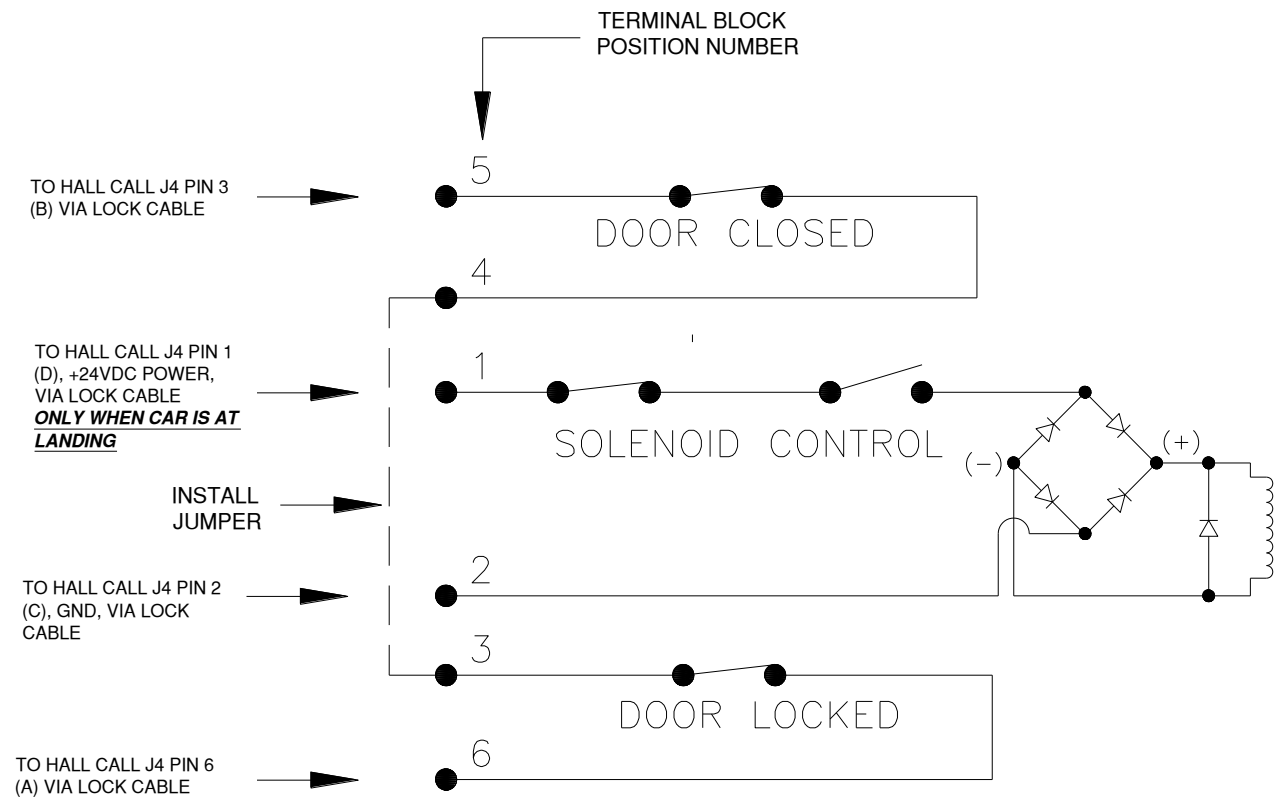

## **DOOR INTERLOCK EMERGENCY ACCESS**

The Inclinator-Honeywell interlock has a lock lift pin for manually unlocking the hoistway door.

If the interlock is being used with an Inclinator-Honeywell Keeper Mounting Bracket Kit or a Pre-hung Flush Door Assembly Kit, a special key is required to unlock the door. Insert the key through the hole and push down (outside of door) to lift the lock pin and unlock the door. This key, Inclinator part number 21301116 Door Interlock Escutcheon key, must be ordered separately.

If mounting the interlock without the Keeper Mounting Bracket, a hole must be drilled in the door to access the lock lift pin. Use the mounting template included in the packaging of the lock for details on the location and size of this hole. To unlock the door, place a long slender screwdriver or 1/4" diameter pin through the hole and push down (outside of door) to lift the lock pin and unlock the door.

**Inclinor Company of America**  
**601 Gibson Blvd.**  
**HARRISBURG, PA 17104**  
**PHONE: 1-800-343-9007 (M-F 8am-5pm EST)**  
**FAX: 717-939-8076 / 8075**  
**[www.inclinor.com](http://www.inclinor.com)**